

# Obiettivo 2030: Generazione Green

Con la scuola per guidare la transizione  
green



DEASCUOLA



a2a  
LIFE COMPANY

per le  
scuole



X\_nano invisible matters

# Nanotecnologie per la transizione energetica

Idee innovative per la transizione

**Fabio Di Fonzo**, co-founder di X\_nano e ricercatore al Center for Nano Science and Technology di IIT a Milano



# DA DOVE VENGO: VASTO IN ABRUZZO



# QUANDO HO DECISO DI DIVENTARE UN FISICO/INGEGNERE?

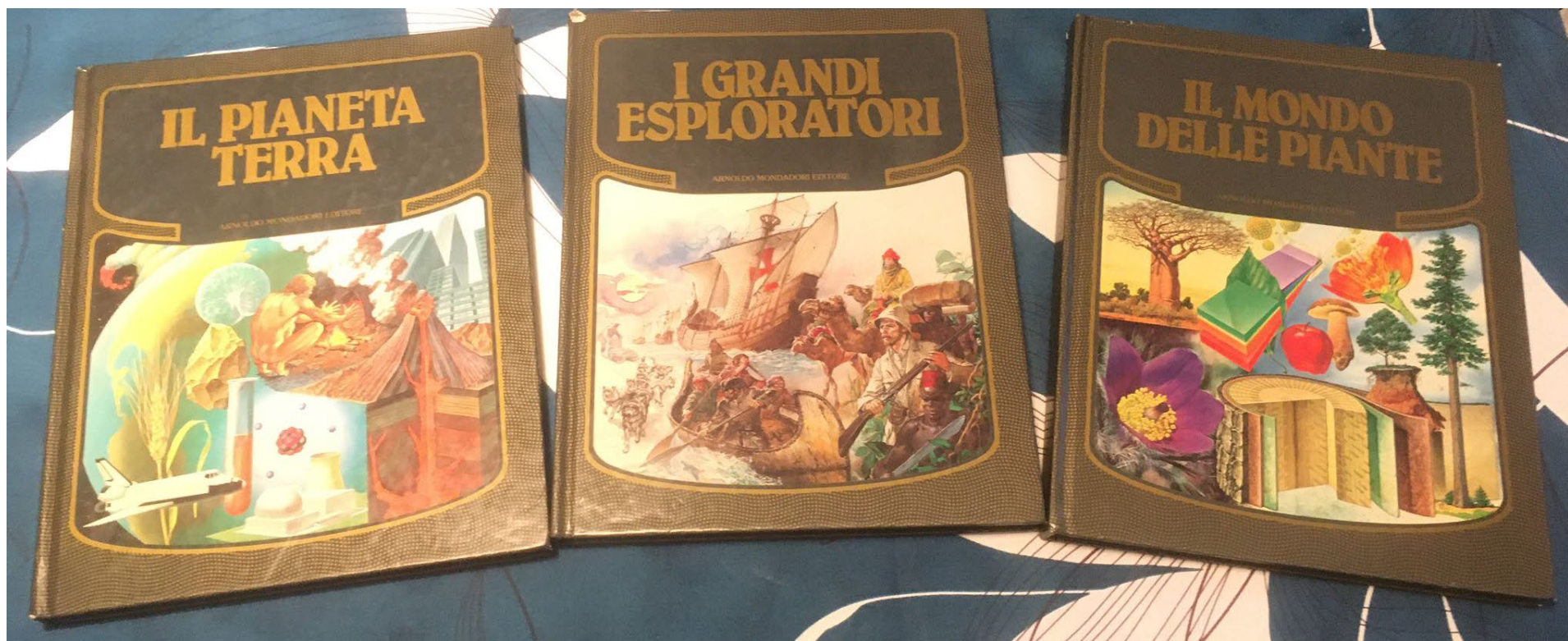

# MITI PERSONALI?

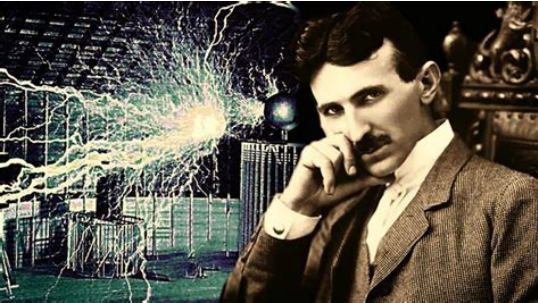
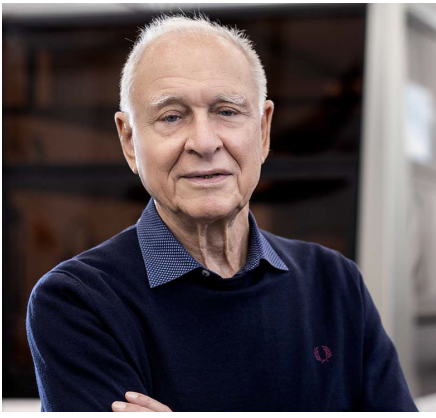
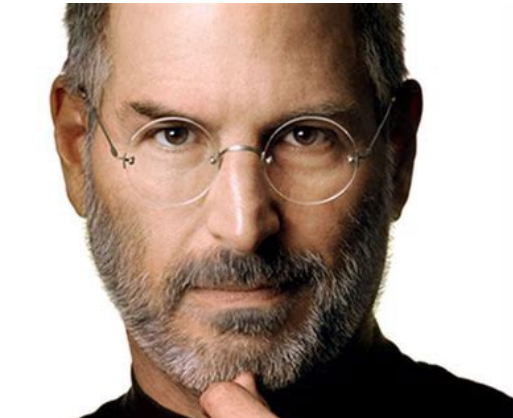
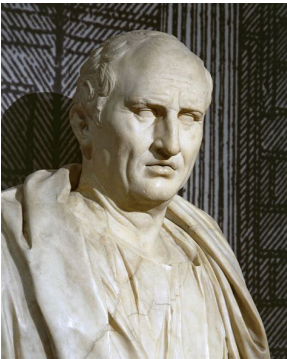
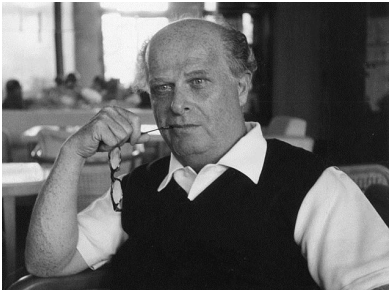
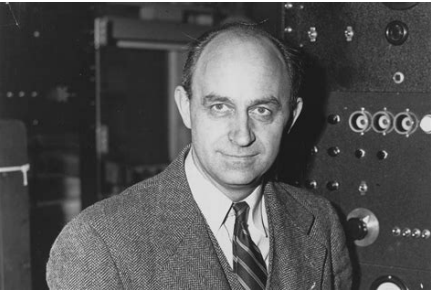

# STUDI



Liceo classico  
(consigliatissimo!)



Ingegneria ambientale (fino al II anno)



Ingegneria meccanica  
Orientamento Energetico-Idrocarburi



Master of Science in Mechanical Eng.



# ESPERIENZE



**2000-2002**

Borsista Dipartimento di Fisica UniMi con Prof. Paolo Milani



**2003-2010**

Dottorato di Ricerca Dipartimento -> Borsista Ing. Nucleare, Politecnico di Milano Prof. Carlo Bottani



**2010-to present (20%)**

Ricercatore->Team Leader-> Technologist Center for Nano Science and Technology Istituto Italiano di Tecnologia

100 pubblicazioni, >10 brevetti, h-index=39, Inserito nella lista top Italian scientist  
**>50 tesi magistrali e >40 dottorati di ricerca dal 2010**

# COSTRUIRE IL FUTURO CON GLI ATOMI

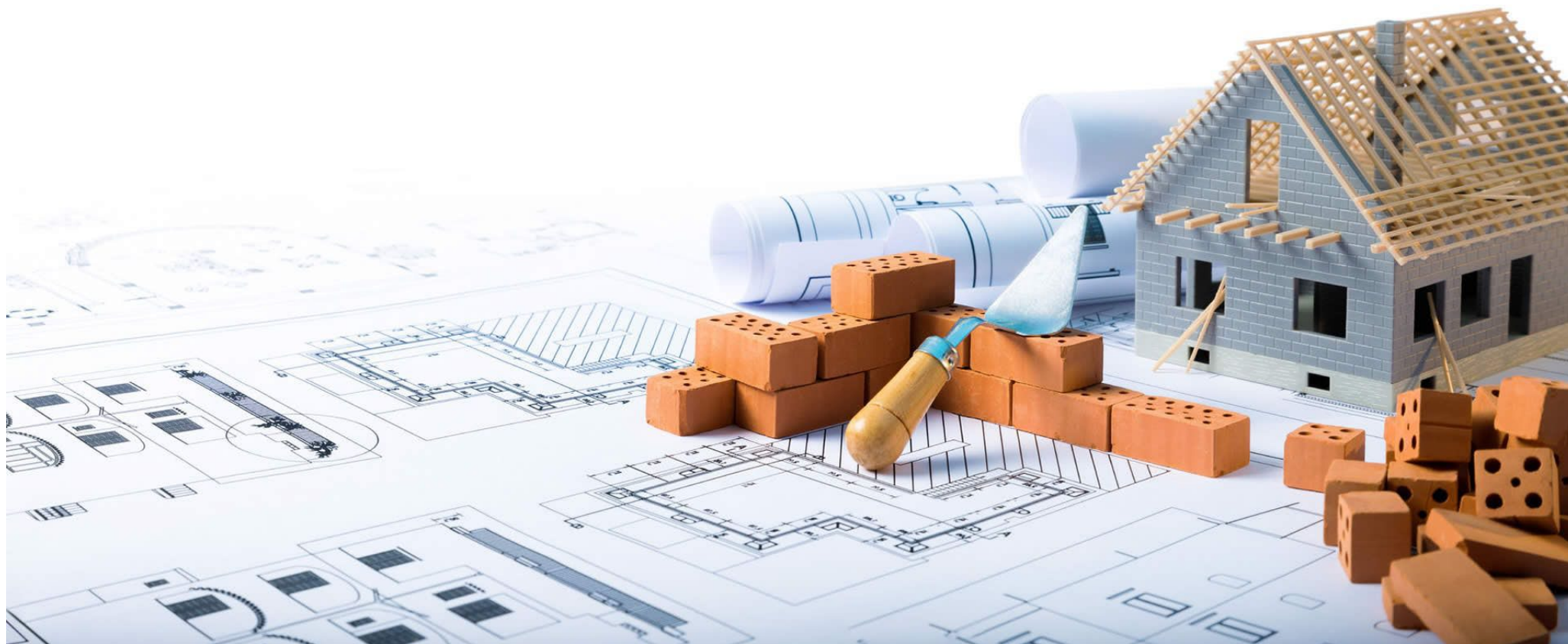

# COSTRUIRE IL FUTURO CON GLI ATOMI



# COSTRUIRE IL FUTURO CON GLI ATOMI

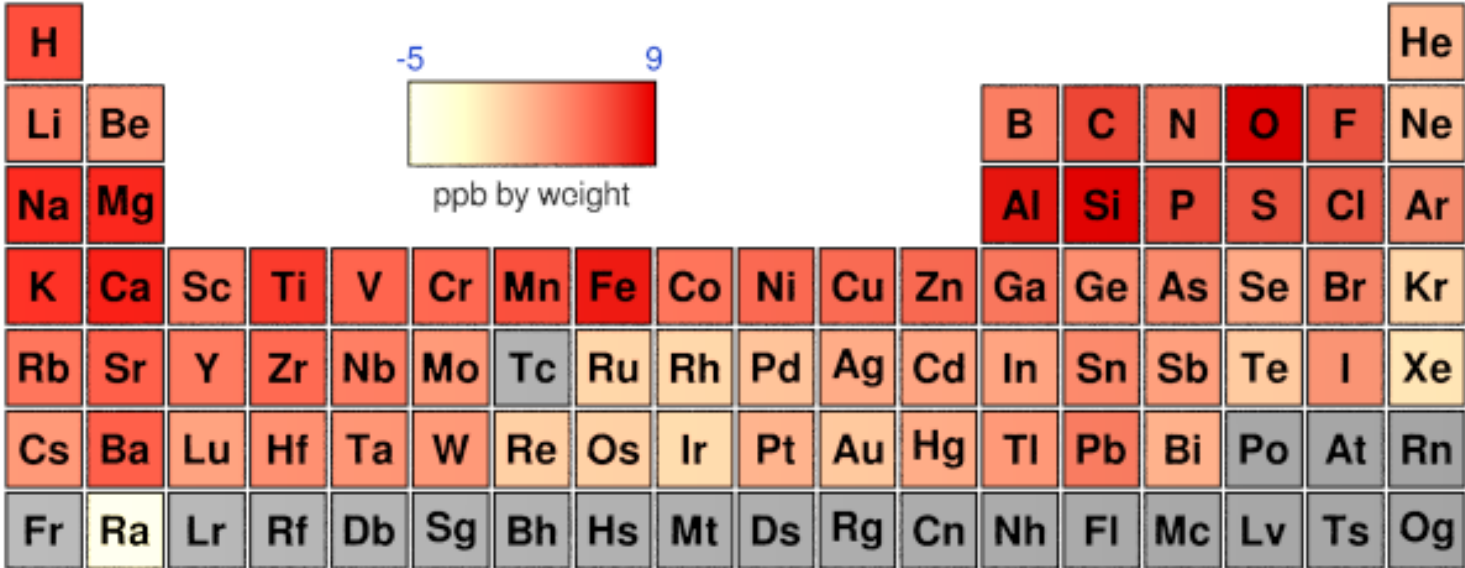

La	Ce	Pr	Nd	Pm	Sm	Eu	Gd	Tb	Dy	Ho	Er	Tm	Yb
Ac	Th	Pa	U	Np	Pu	Am	Cm	Bk	Cf	Es	Fm	Md	No



Abundance in Earth's crust (by weight) (logs)

[www.webelements.com](http://www.webelements.com)

© Mark Winter

# COSTRUIRE IL FUTURO CON GLI ATOMI

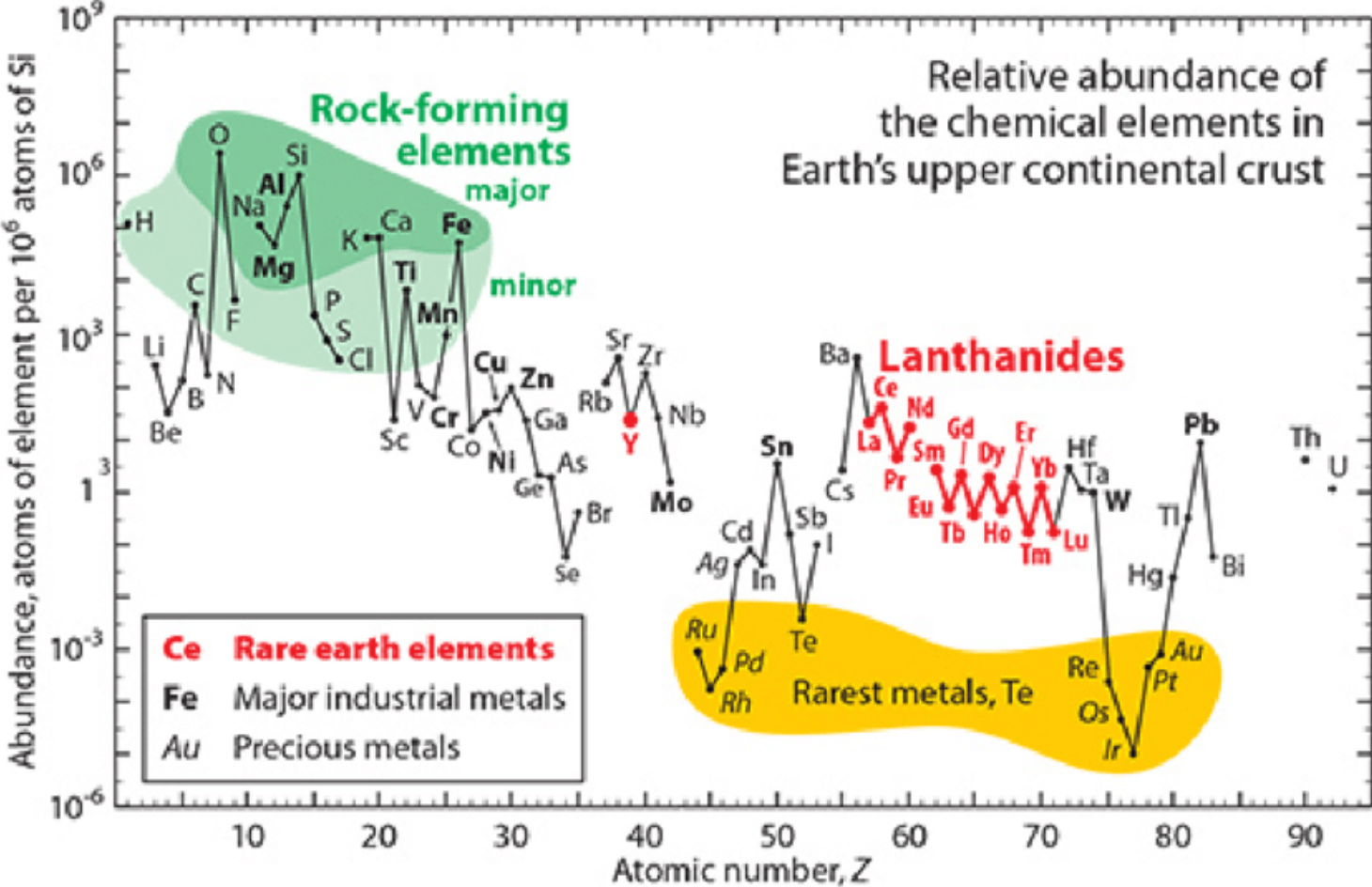

# COME UN CHIMICO USA GLI ATOMI

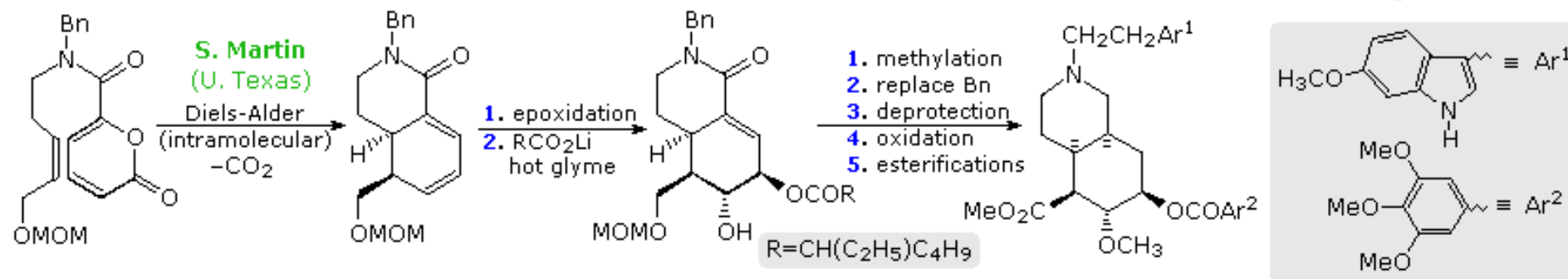
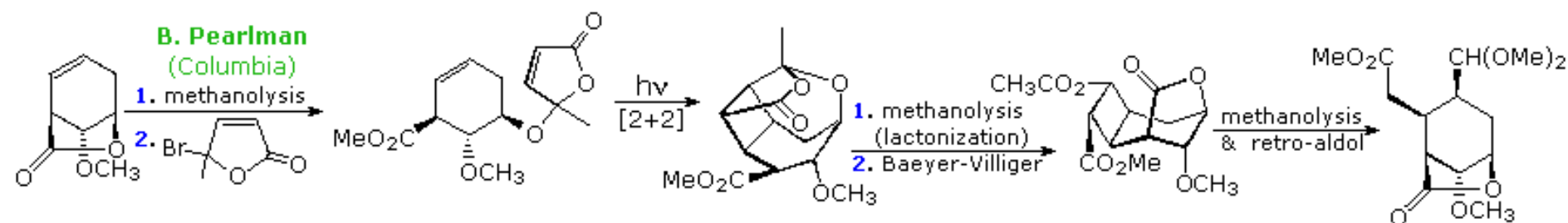
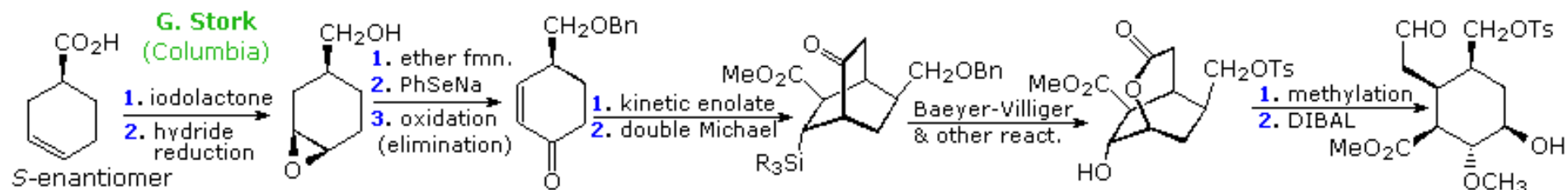

# COME UN INGEGNERE/FISICO/SCIENZIATO DEI MATERIALI USA GLI ATOMI

- **Nano-domini ordinati** (~10 nm) in una matrice di TMD amorfo
- Piani distorti di S-Mo-S con alta densità di difetti
- Alta densità di difetti -> alta attività catalitica

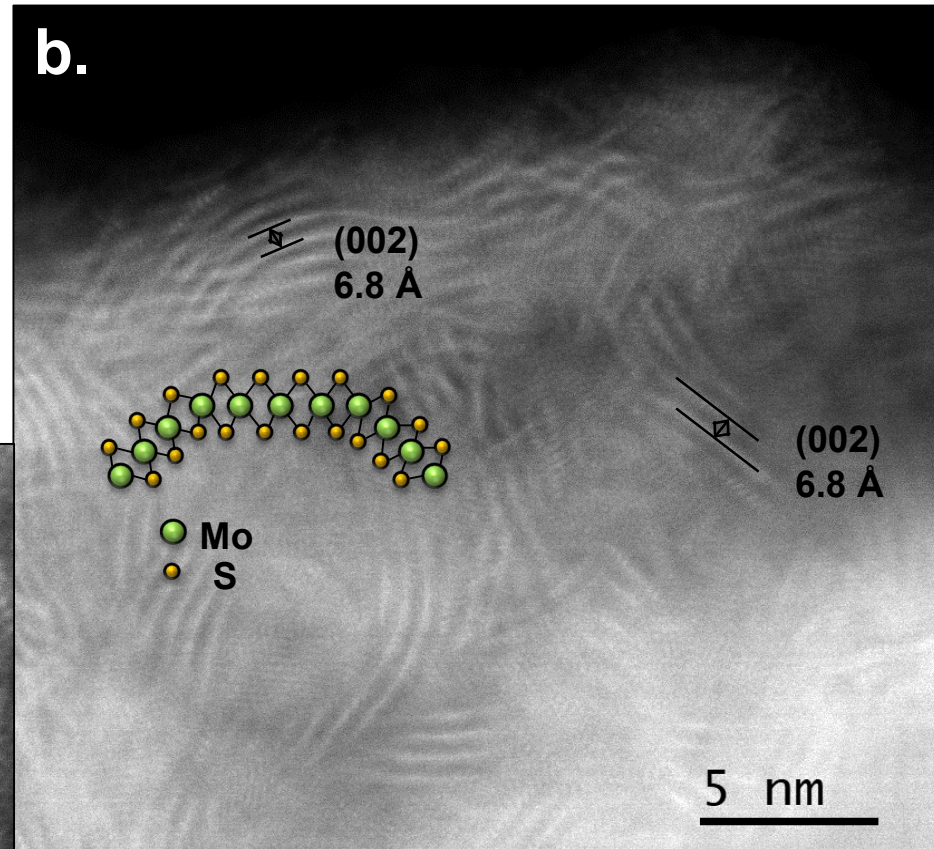
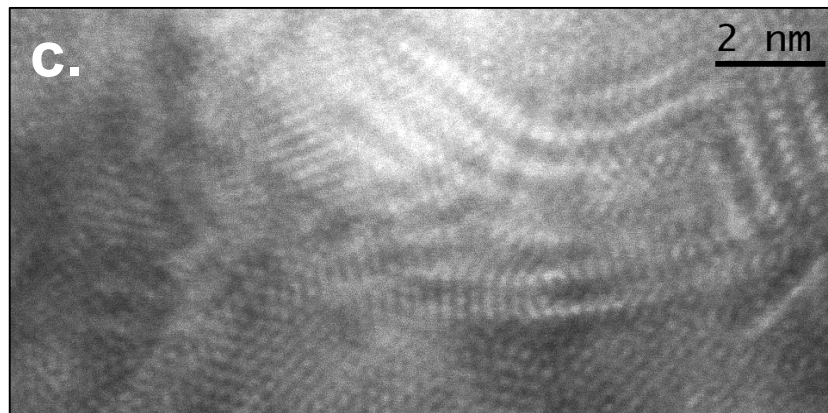

*G. Giuffredi et al. Small 2020*

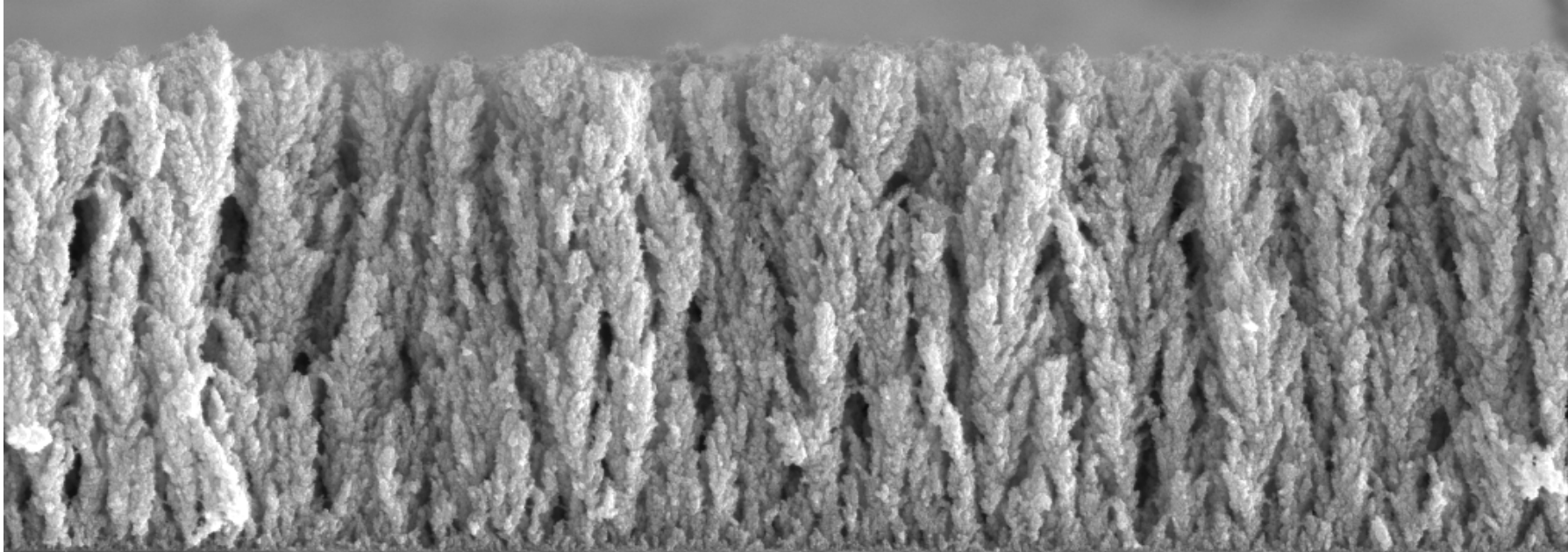

# COME UN INGEGNERE/FISICO/SCIENZIATO DEI MATERIALI USA GLI ATOMI

Nanostrutture di  $\text{TiO}_2$ ,  $\text{TiN}$ ,  $\text{WO}_3$ ,  $\text{V}_2\text{O}_5$  per catalisi, celle solari, celle a combustibili, elettrolizzatori, finestre intelligenti, etc



SEM HV: 10.0 kV	WD: 6.40 mm		MIRA3 TESCAN
SEM MAG: 25.0 kx	Det: In-Beam SE	2 $\mu\text{m}$	
View field: 11.1 $\mu\text{m}$	Date(m/d/y): 12/06/19	EM Lab (IIT-PoliMi)	

*Perego ACS Appl. Energy Mater.*  
2019  
*F. Arena ChemElectroChem* 2021  
*G. Rossetti Electrochimica Acta*  
2022

# NANOMATERIALS AND NANOMANUFACTURING FOR ENERGY AND ENVIRONMENT (i miei 13 anni in IIT)

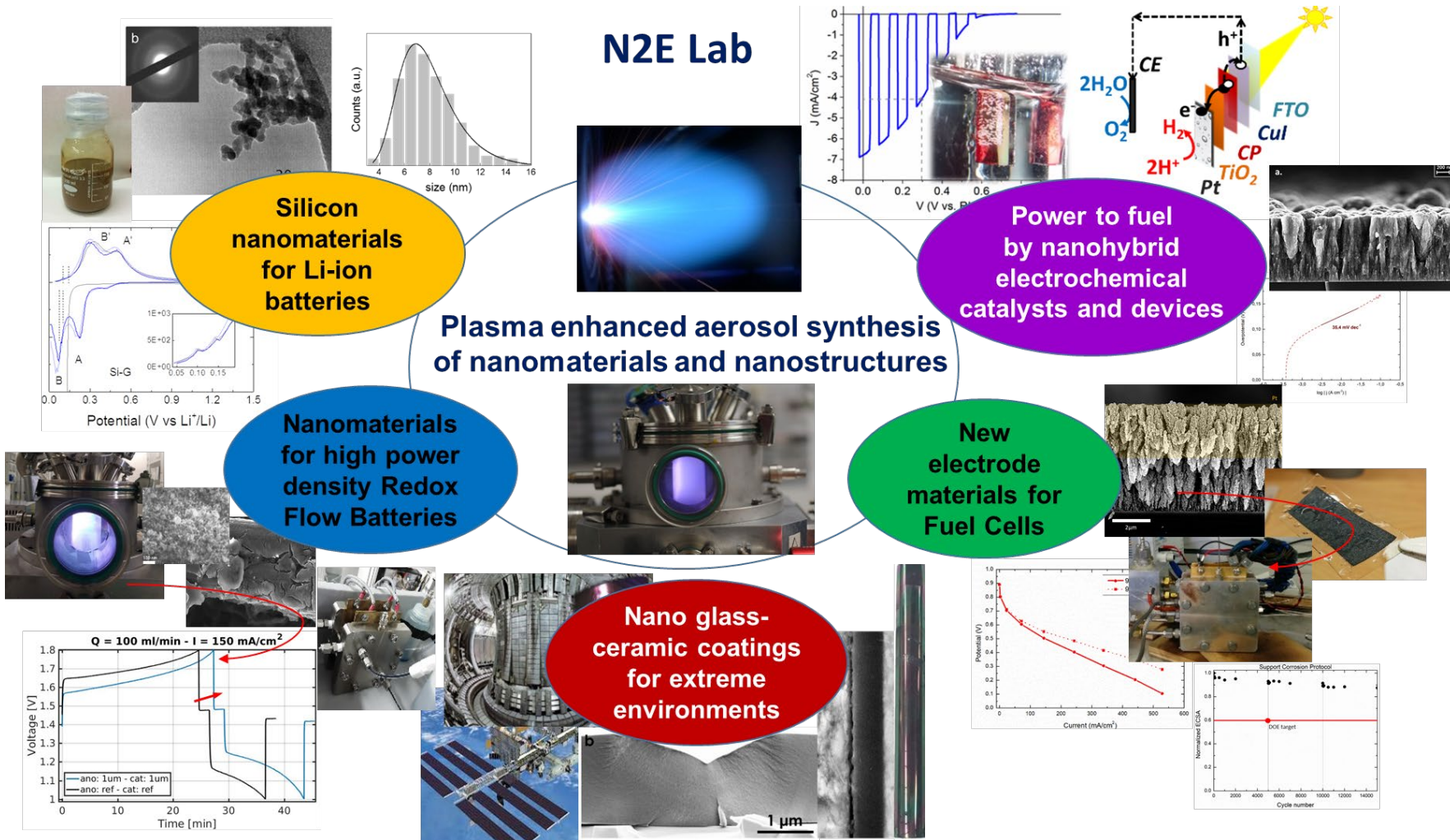



Le nanotecnologie  
sono belle,  
ma c'è urgenza di  
agire per il  
cambiamento  
climatico

# ATMOSPHERIC CARBON DIOXIDE

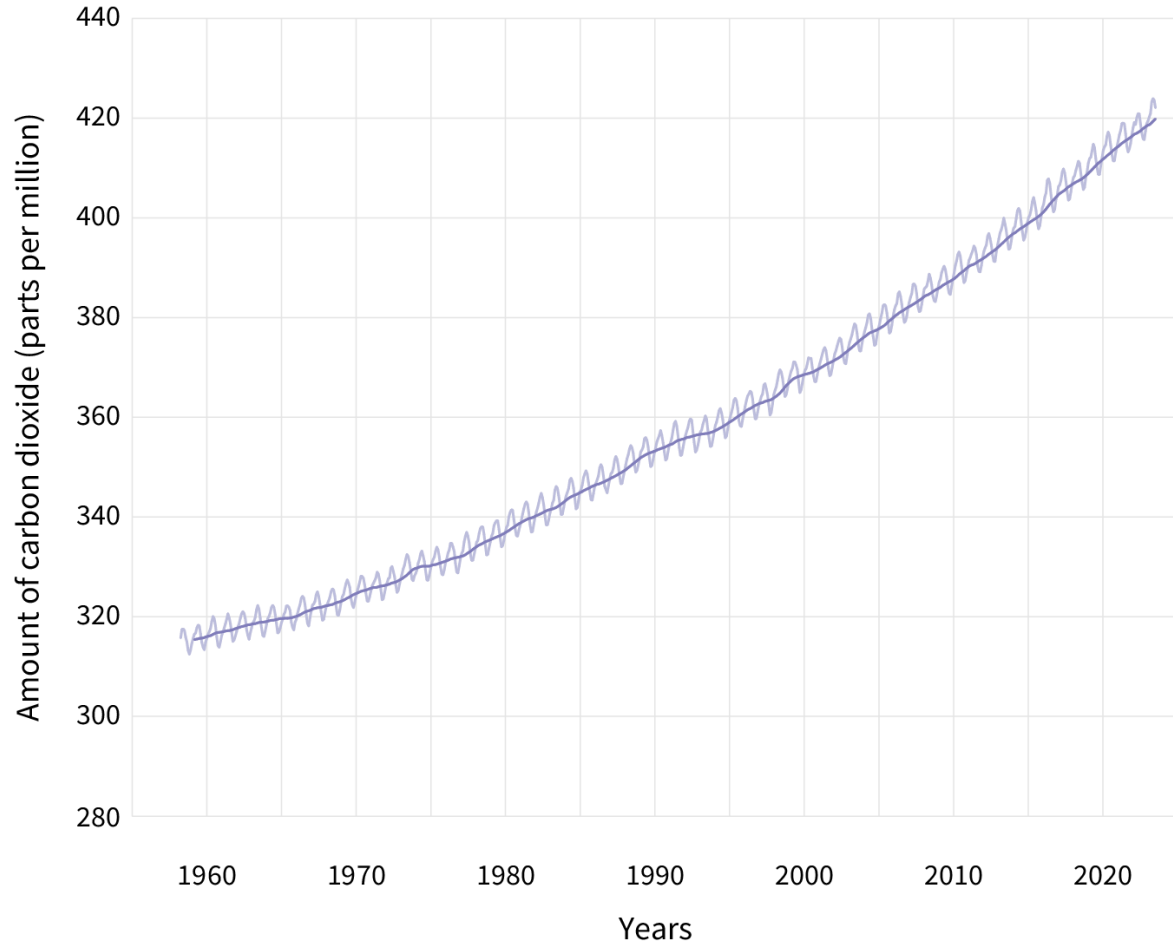

## Global Climate Dashboard

Tracking climate change and natural variability over time

Sort by Indicator: Climate Change

### Greenhouse Gases



In 2021, the combined heating influence of all human-produced greenhouse gases was 49 percent higher than it was in 1990.

[Learn more](#)

### Arctic Sea Ice



Since the start of the satellite era in 1979, the extent of ice covering the Arctic Ocean at the end of summer has shrunk by more than 40 percent.

[Learn more](#)

### Carbon Dioxide



The amount of carbon dioxide in the atmosphere has risen more than 45 percent since people began burning fossil fuels for energy. It hit a new high of 414.7 parts per million in 2021.

[Learn more](#)

### Mountain Glaciers



Since 1980, the cumulative ice loss from a reference network of mountain glaciers is equivalent to slicing an 87-foot-thick slab off each glacier. The rate of loss is roughly doubling each decade.

[Learn more](#)

### Ocean Heat



The ocean is storing 91% of the excess heat from global warming, contributing to sea level rise, ice shelf retreat, and stress on marine life.

[Learn more](#)

### Sea Level



Sea level has risen between 8 and 9 inches since 1880. The rate of sea level rise more than doubled from 2006–2015 compared to the rate throughout most of the twentieth century.

[Learn more](#)

### Spring Snow



Since 1967, spring snow cover has shrunk by 1.4 percent per decade in April, 4.1 percent per decade in May, and 12.9 percent per decade in June.

[Learn more](#)

### Incoming Sunlight

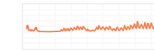

The sun's total brightness varies by an average of 0.1 percent over an 11-year cycle, but there has been very little net change over the last century.

[Learn more](#)

### Surface Temperature



Global average surface temperature has risen 0.14 degrees Fahrenheit per decade since 1880. The rate of warming has more than doubled since 1981.

[Learn more](#)

15 February 2023



# Nanotecnologie: opportunità di sviluppo e business



per le  
scuole

- 1.200 t di grafite per GWh di capacità produttiva di batterie
- taglia media 40 GWh
- 40 Gigafactory previste nell'UE
- **2.000.000 t/a di grafite BG sono necessari solo nell'UE**

# GRAFITE PER IL MERCATO DELL'ANODO DELLA BATTERIA AGLI IONI DI LITIO

Grafite per la richiesta di batterie agli ioni di litio (M ton)

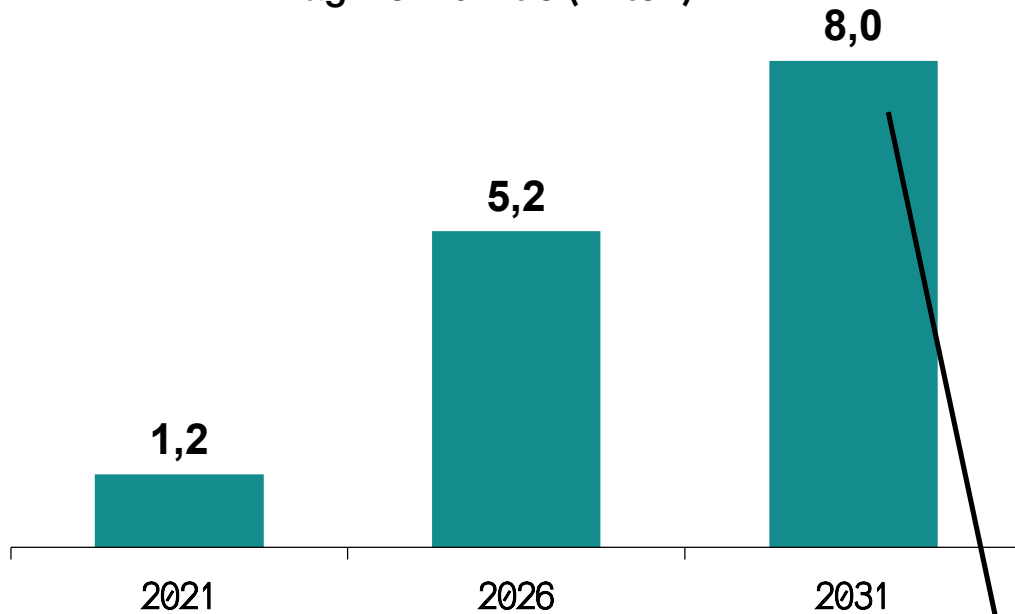

Più di 320 fabbriche di batterie in cantiere per una capacità combinata di oltre 6.500 GWh entro il 2031 (corrispondenti a materiali anodici da 7,8 Mt)

Source: «Benchmark Mineral Intelligence, July 2022»

Previsione del prezzo dell'anodo di grafite sintetica (\$/ton)

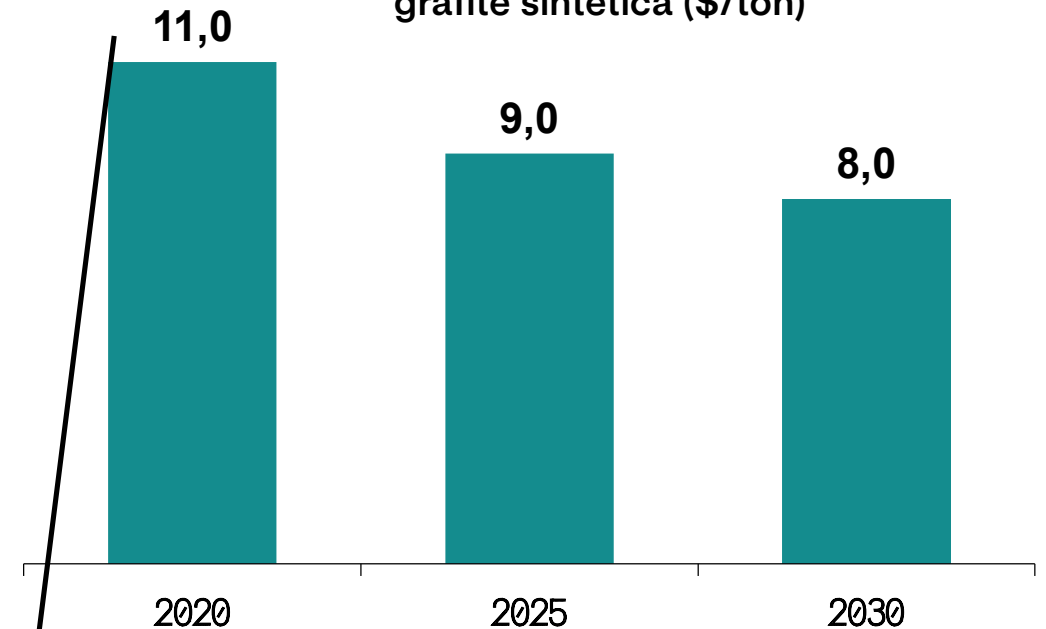

La grafite sintetica per anodo costa circa 10 volte di più della grafite naturale (che si aggira tra i 500 e i 1.500 \$/ton)

Source: Novonix «Investor presentation 2020»

# GRAFITE SINTETICA SOSTENIBILE PER BATTERIE AGLI IONI DI LITIO

## Opportunità di mercato

La grafite con ~ 500% CAGR è uno dei materiali più importanti per la mobilità futura

Materials demand tons CAGR (2018-2050)

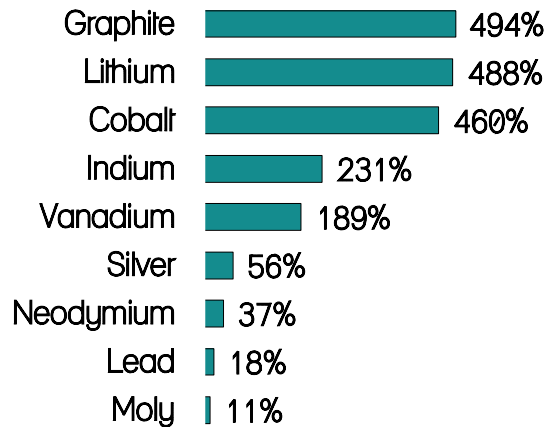

## Criticità

La catena di approvvigionamento della grafite dipende interamente dalla Cina e si basa su un processo altamente non sostenibile (20 kg di CO2/kg di grafite sintetica)

Natural graphite processing capacity

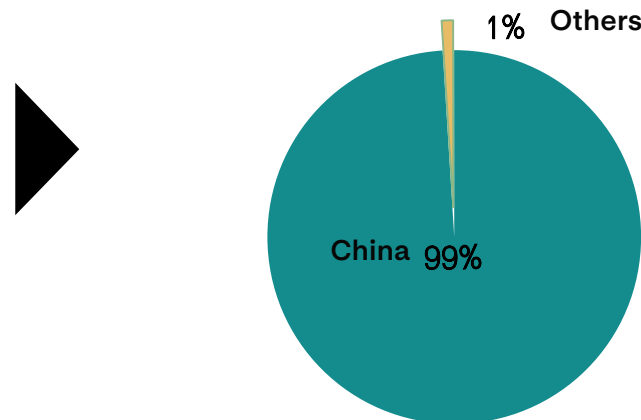

## Soluzione X-nano

**Pirolisi di gas naturale (anche di origine rinnovabile)** localizzati in prossimità della domanda e in grado di:  
**Elevata velocità (>100 kt /anno per impianto)**  
**Elevata purezza (senza metalli)**  
**Alte prestazioni**  
**Zero emissioni**

Stato (TRL: 3)  
Processo: fase iniziale  
Brevetto: un brevetto depositato

Source; 2020 World Bank Minerals for Climate Action: The Mineral Intensity of the Clean Energy Transition

Source; Wood Mackenzie, "The implausibility of accelerated decarbonisation pathways"

# KEY DATA

 **Spin-off dell'Istituto Italiano di Tecnologia** fondato per sviluppare applicazioni delle nanotecnologie e dei nanomateriali nel campo della transizione energetica, con focus su materiali attivi ed abilitanti per produzione e accumulo di energia.

 Milano, @CNST (IIT-Polimi) Via Rubattino 81

 **16 collaboratori+4 executive+tesisti e tirocinanti**

- 2 Responsabili/Dirigenti
- 4 Postdocs
- 6 PhD
- 4 MS

 **Creiamo nanomateriali e nanorivestimenti abilitanti per il settore dell'energia**, mediante processi attivati da plasma, laser and calore in getti subsonici e supersonici

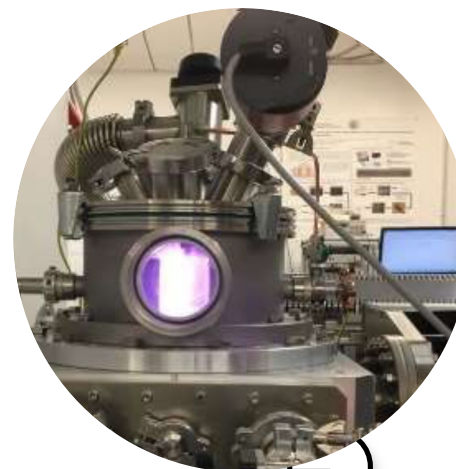

# MADE BY PEOPLE



CEO P. Murtti PhD



CSTO F. Di Fonzo PhD



CFO C. Bernardocchi



CEO FN L. Rizzi PhD



CEnO F. Brandoplessè



CAO T. Gronchi

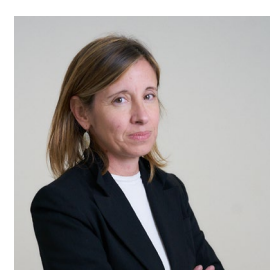

## VISION

“Siamo degli entusiasti della tecnologia motivati dalla curiosità e dall’urgenza di contribuire al cambiamento verso la sostenibilità creando valore e opportunità. Vogliamo un future nel quale l’energia sia la soluzione e non il problema”

## MISSION

“Attraverso materiali invisibili, materializzare la transizione energetica”

Spin-off of



Equity and  
industrial partner



# TECNOLOGIE DI PRODUZIONE

X-nano

Tecnologie

## Termico

**Tecnologia** Decomposizione termica del vapore in alta pressione (fino a 70 bar) con getti supersonici

**Applicazione** Produzione di massa di nanomateriali a base di carbonio

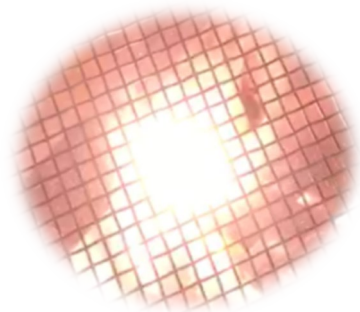

## Plasma

**Tecnologia** Crescita chimica da vapore assistita da plasma in flussi supersonici

**Applicazione** Film porosi nanostrutturati su substrati e/o nanomateriali dispersi

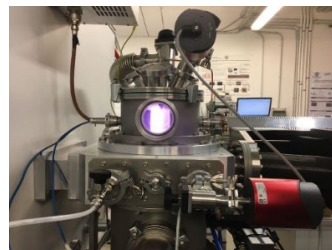

## Deposizione laser pulsata PLD

**Tecnologia** Sputtering fisico assistito da laser pulsato in flussi supersonici

**Applicazione** Rivestimenti densi di materiali complessi (ossidi complessi) per ambienti estremi



# NANOMATERIALI PER LA TRANSIZIONE ENERGETICA

## X-nano

### Applicazioni

#### Batterie

- Grafite sintetica pulita per batterie agli ioni di litio per la mobilità elettrica, anodi
- Nano silicio – Celle allo zolfo per batterie aerospaziali ad alta energia
- Nano catalizzatori per elettrodi ad alte prestazioni in batterie a flusso redox

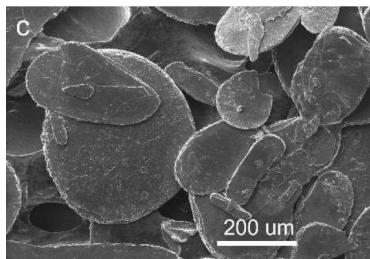

#### Idrogeno

- Produzione di H<sub>2</sub> per decomposizione termica di idrocarburi fossili o rinnovabili (H<sub>2</sub> turchese)
- Nano catalizzatori per elettrodi ad alte prestazioni in elettrolizzatori alcalini (verde H<sub>2</sub>)

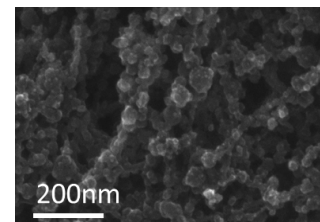
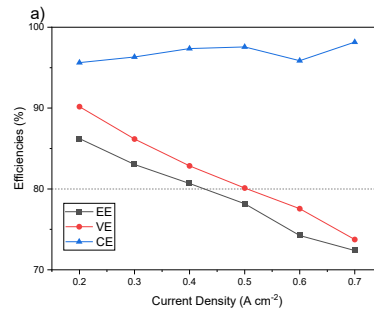

#### Nucleare

- Rivestimenti protettivi per rivestimenti di combustibile LFR (Lead Fast Reactors) di 4a generazione
- Rivestimenti protettivi per combustibile resistente agli incidenti (ATF) nei reattori ad acqua leggera
- Strati antipermeazione H<sub>2</sub> per reattori a fusione nucleare

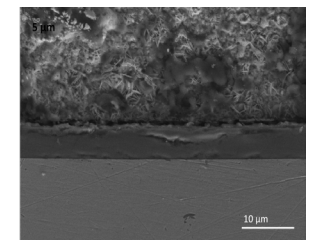
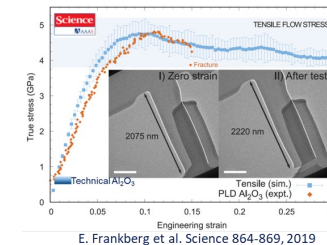

# Grafite sintetica sostenibile per batterie e H<sub>2</sub> turchese



DEASCUOLA



a2a  
LIFE COMPANY

per le  
scuole

# DISRUPTING THE BG-GRAPHITE VALUE CHAIN

a

## Synthetic graphite

### Step 1: Pre-treatment

- (1) Carbon precursor (such as coke)
- (2) Calcination soft carbon
- (3) Crushing, grinding
- (4) Classifying

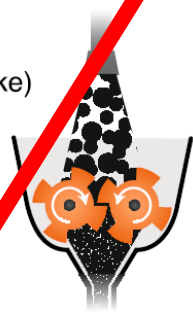

### Step 2: Graphitization

- (1) Graphitization (>2,500 °C)

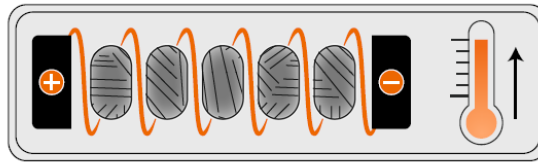

### Step 3: Particle refinement

- (1) Conditioning
- (2) Grinding
- (3) Classifying
- (4) Coating

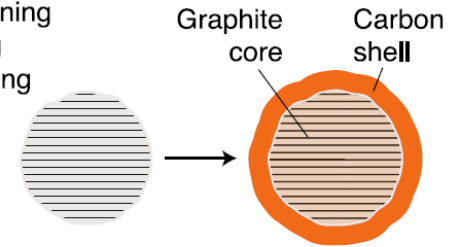

b

## Natural graphite

### Step 1: Mining and flotation

- (1) Mining from graphite ore
- (2) Mechanical separation
- (3) Flotation
- (4) ...



### Step 2: Material processing

- (1) Micronization
- (2) Spheroidization
- (3) Purification (>99.99% purity)

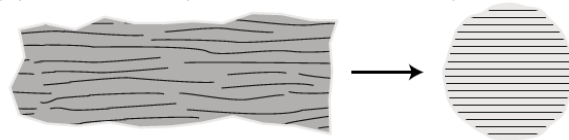

### Step 3: Particle refinement

- (1) Conditioning
- (2) Grinding
- (3) Classifying
- (4) Coating

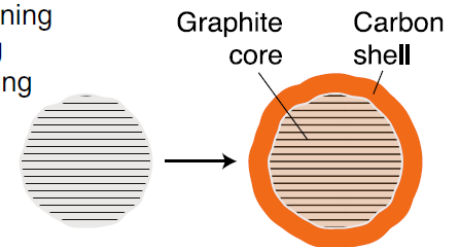

# PERCHÉ POSSIAMO AFFRONTARE QUESTA SFIDA

Reattore disegno

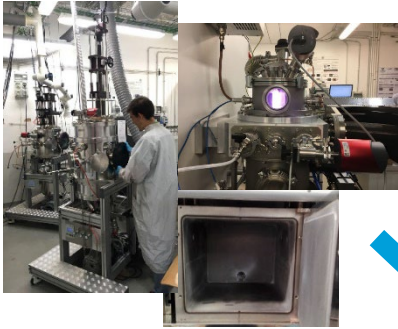

Processi

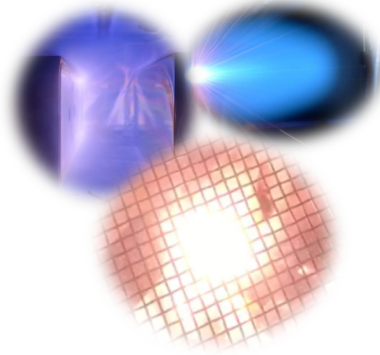

Materiali

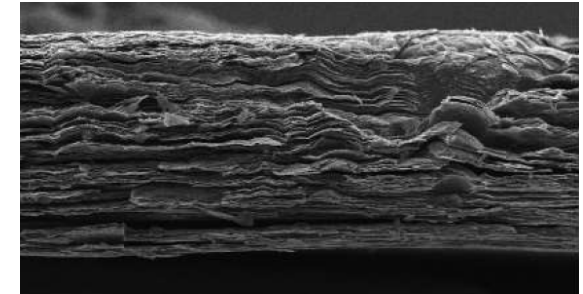
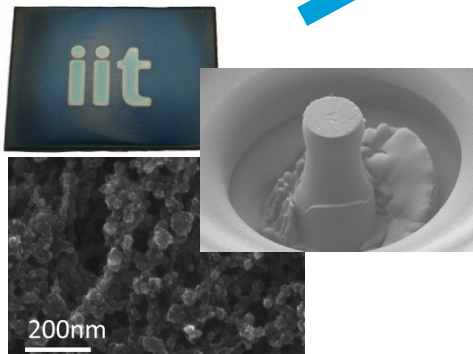

Grafite verde e nerofumo da pirolisi del gas naturale:

- Purezza intrinsecamente  $\approx 100\%$
- $\approx 0$  CO<sub>2</sub>/emissioni gas clima-alteranti

# REATTORE DI PIROLISI PENSATO PER ESSERE SCALATO

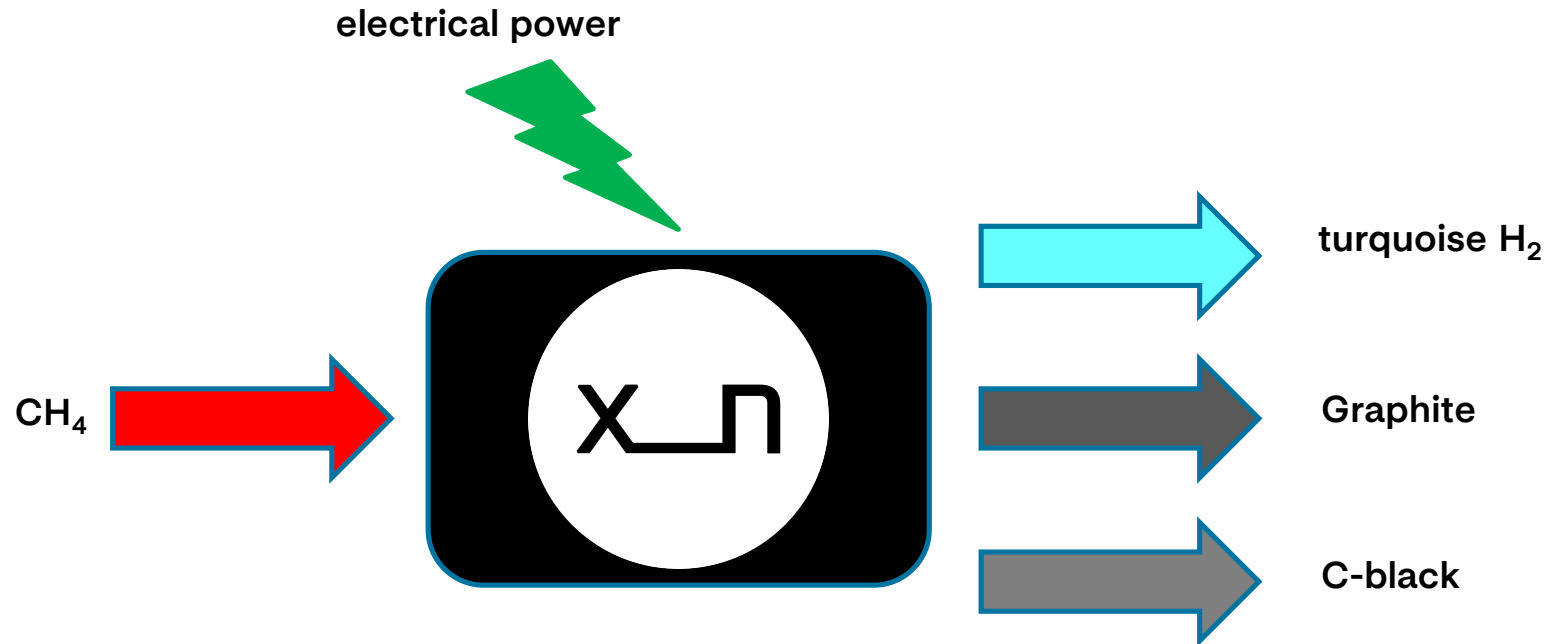

## Roadmap

2022: kg/y scale reactor (POC) **in operation**

2024: 10 ton/y, 30 kWe scale reactor (Pyro1-TechDemo)

# REATTORE DI PIROLISI PENSATO PER ESSERE SCALATO

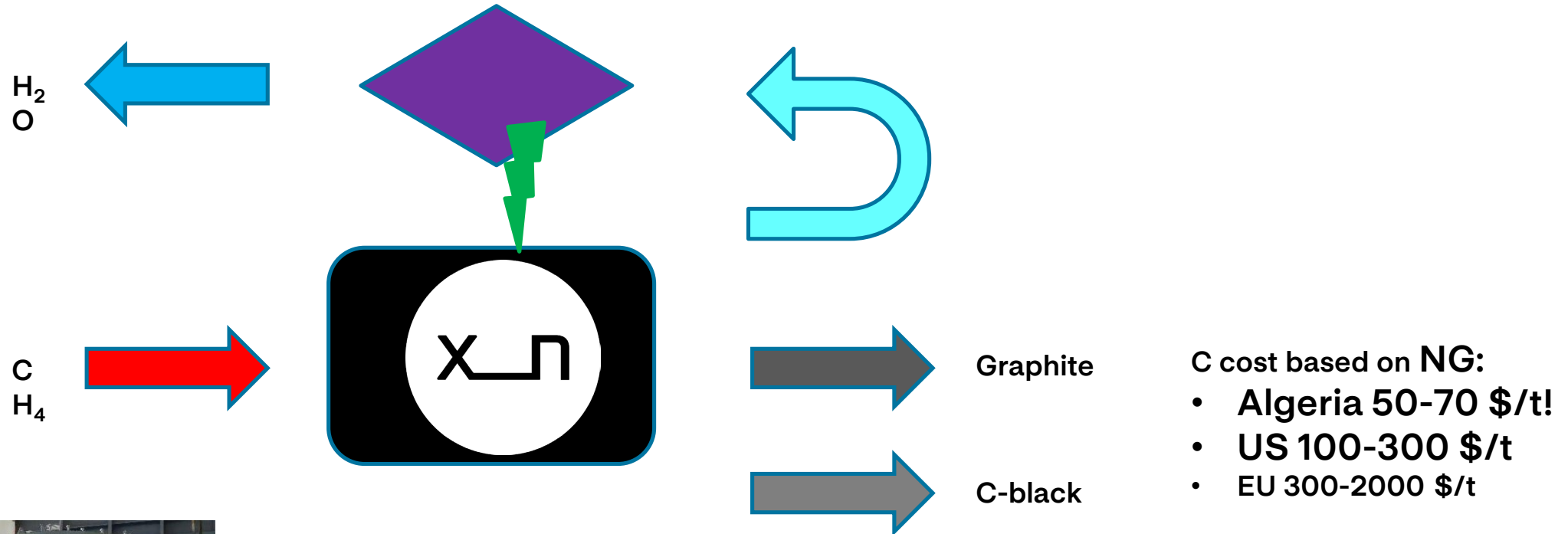

## Roadmap

- 2022: kg/y scale reactor (POC) **in operation**
- 2023: 10 ton/y, 30 kWe scale reactor (Pyro1-TechDemo) **design/procurement**
- 2026: 10 kton/y, 70 MWe scale reactor (Pyro2-Pilot) **10s M€ scale**
- 2030: 100 kt, 500 MWe scale reactor (Pyro3-DEMO) **100s M€ scale**

# UN ATTORE IMPORTANTE NELL'ARENA DELL'IDROGENO TURCHESE



CO<sub>2</sub> free  
electrical power

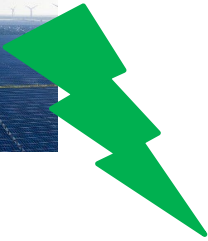

CH<sub>4</sub>

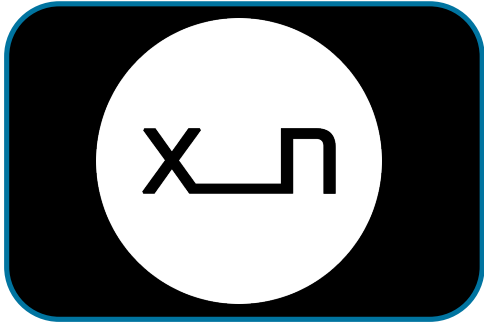

turquoise H<sub>2</sub>



C-black



graphite



steel mills



concrete



petrochemical

# PIROLISI MOLTO PIÙ PRODUTTIVA PER WATT DI ENERGIA RINNOVABILE

## H<sub>2</sub> from water electrolysis

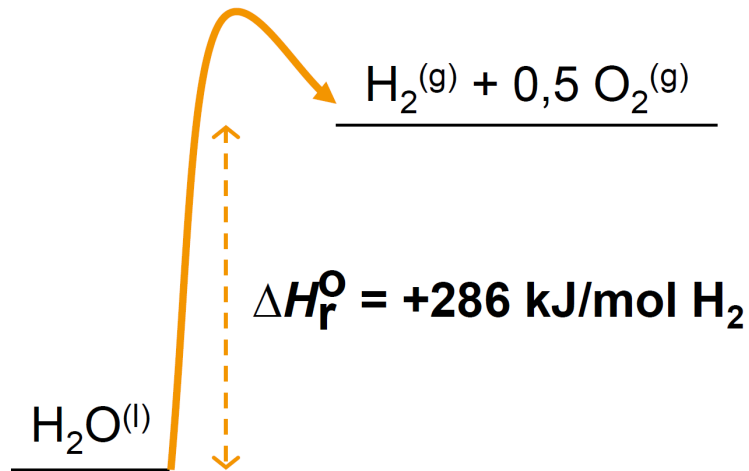

- Very high energy demand
- Water as a raw material
- First small industrial-scale plants

## H<sub>2</sub> from methane pyrolysis

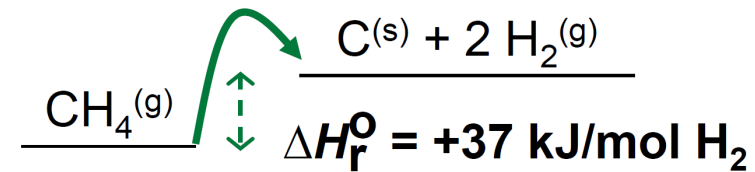

LHV H<sub>2</sub> = 237 kJ/mole H<sub>2</sub>  
 LHV CH<sub>4</sub> = 802 kJ/mole CH<sub>4</sub> } LHV ratio = 59%

- Low energy demand
- Fossil raw material
- Solid carbon as 2<sup>nd</sup> product
- First pilot plants



# PIROLISI COME STRUMENTO PER L'ELIMINAZIONE DELLA CO2 DALL'ATMOSFERA(... tanto tanto in là!)

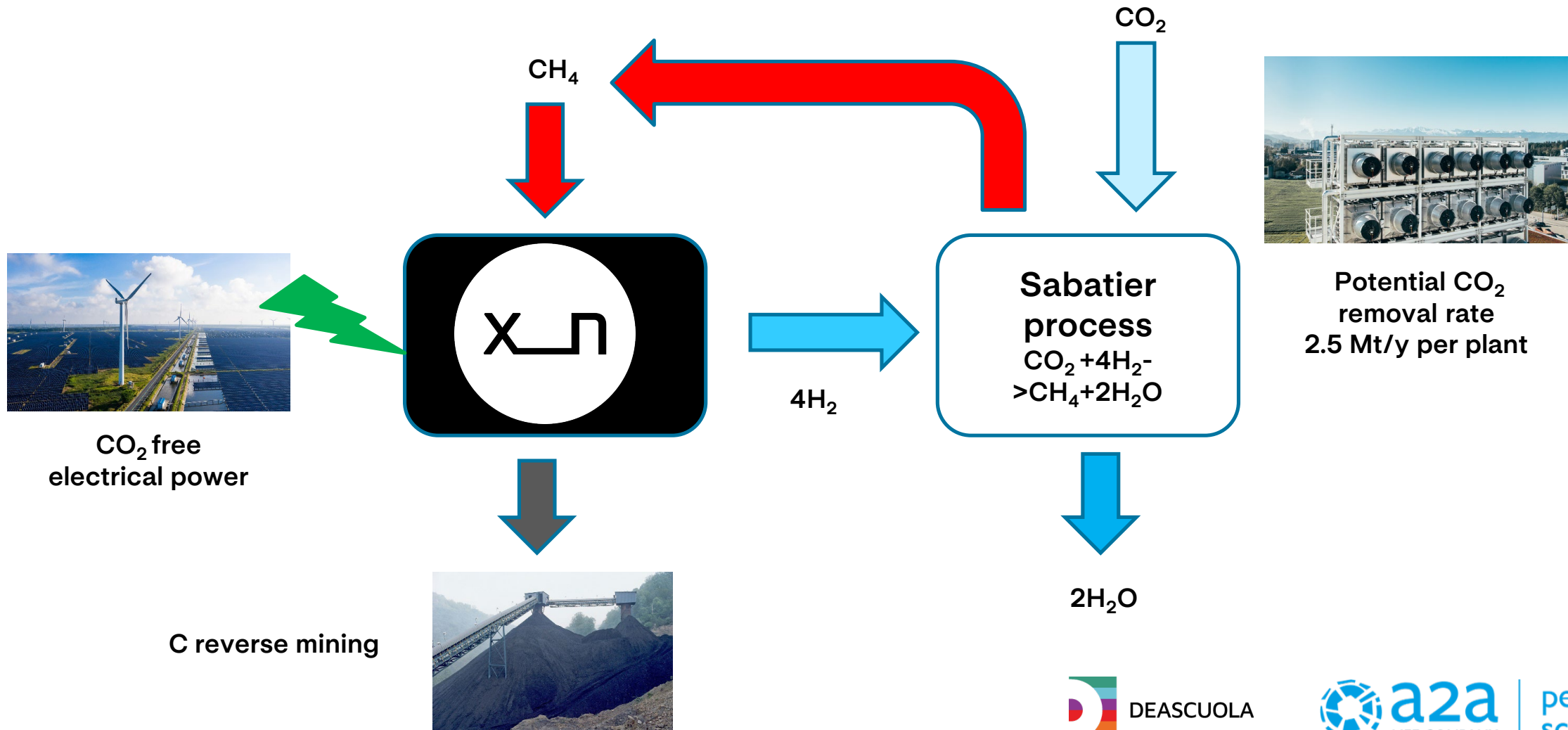

# Nucleare sostenibile (economia, società, ambiente)



DEASCUOLA



a2a  
LIFE COMPANY

per le  
scuole

# L'ENERGIA NUCLEARE SARÀ UNA PIETRA MILIARE PER IL FUTURO DELLA TRANSIZIONE ENERGETICA



*Il 2 dicembre 2023 si è svolto presso Expo City Dubai, negli Emirati Arabi Uniti, l'evento Tripling Nuclear Energy by 2050, Net Zero Nuclear Event, in occasione della Conferenza delle Nazioni Unite sui cambiamenti climatici UNCCC. (Dean Calma / AIEA)*

Alla COP28 di Dubai, i leader di 22 paesi di quattro continenti hanno annunciato la triplicazione della capacità globale di energia nucleare entro il 2050 per raggiungere gli obiettivi climatici e le esigenze energetiche.

La storica dichiarazione ha invitato la Banca Mondiale, le banche di sviluppo regionali e le istituzioni finanziarie internazionali a includere il nucleare nei loro prestiti, sottolineando al contempo la necessità di catene di approvvigionamento sicure per accelerare la diffusione della tecnologia

# Why is Germany so terrified of nuclear power?

Decades of green scaremongering have brought Germany to the brink of blackouts.



**Figure 44 - The Declining Costs of Renewables vs. Traditional Power Sources**

### Selected Historical Mean Costs by Technology

LCOE values in US\$/MWh \*

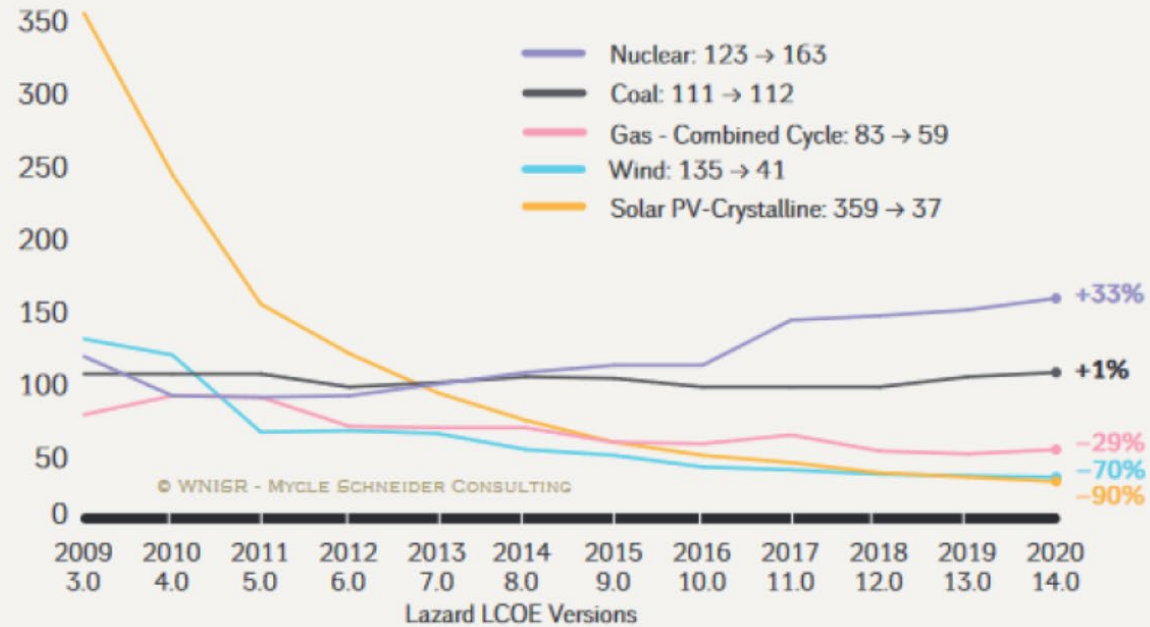

\* Reflects total decrease in mean LCOE since Lazard's LCOE VERSION 3.0 in 2009.

Source: Lazard Estimates, 2020<sup>1242</sup>

#### Notes

LCOE=Levelized Cost of Energy

\*This graph reflects the average of unsubsidized high and low LCOE range for a given version of LCOE study. It primarily relates to the North American renewable energy landscape but reflects broader/global cost declines.

# NUCLEAR ENERGY PRODUCTION NOWADAYS: A TIME FOR CHALLENGES

## ➤ Cosa c'è di sbagliato nel nucleare oggi?



## ➤ Problemi sociali:

- Politica
- Politiche energetiche nazionali
- Accettazione da parte del pubblico

## ➤ Problemi tecnologici:

- Sicurezza delle operazioni
- proliferazione di materiali fissili (ad es. Pu per bombe)
- utilizzo delle risorse (disponibilità limitata di U)
- produzione di scorie nucleari

⇒ Il "must" delle centrali elettriche di futura generazione è quello di essere più sostenibili (cioè verdi), più sicure e più protette

# REATTORI AD ACQUA PRESSURIZZATA (PWR)

## Most dominantly used Nuclear Reactors worldwide

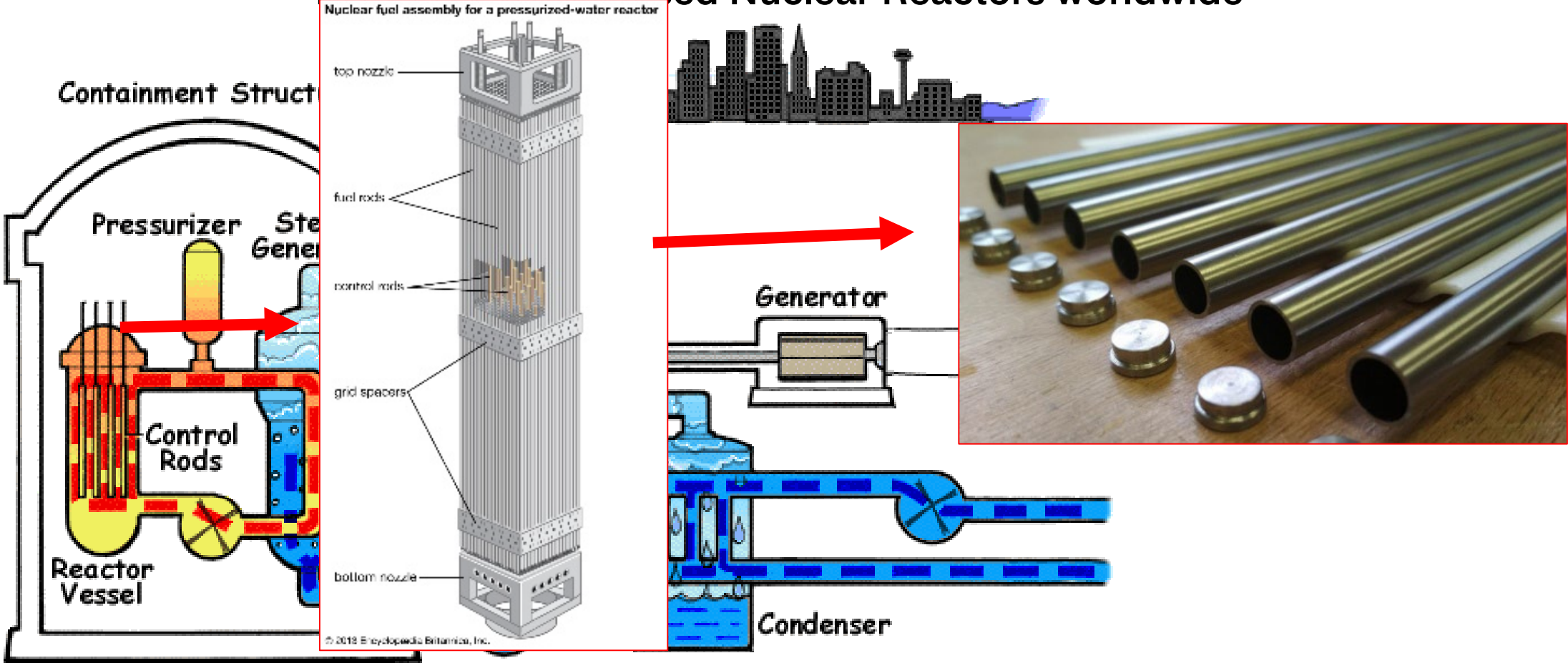

# RIVESTIMENTI CERAMICI AMORFI PER APPLICAZIONI NUCLEARI

Ceramiche amorphe "duttile"



## Mechanical performance

Ductility, hardness, strength

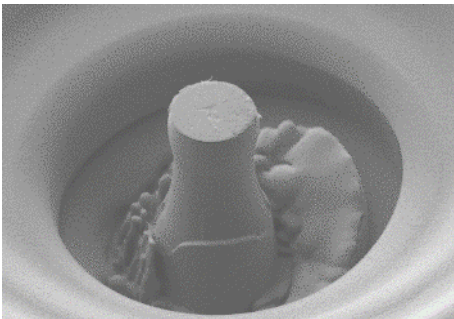

F. Garcia Ferré et al., *Acta Mater* (2013)  
 E. Frankberg et al., *Science* (2019)  
 E. Frankberg et al., *Adv. Mater* (2023)

## H<sub>2</sub>/D<sub>2</sub>/T<sub>2</sub> permeation Amorphous structure

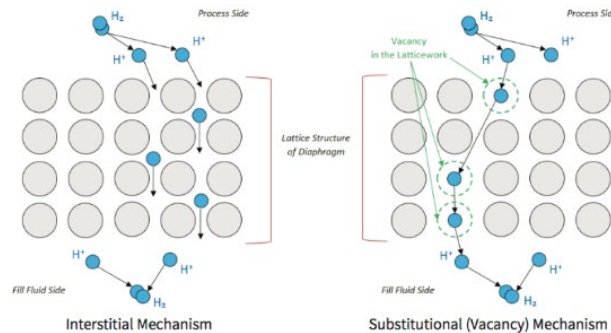

## Corrosion resistance

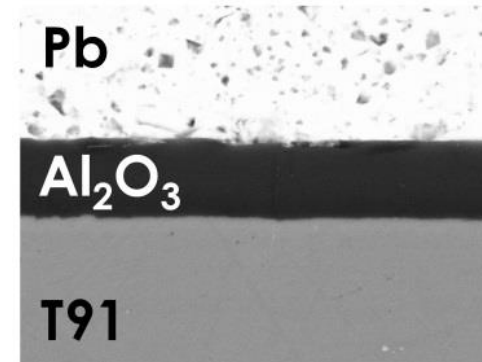

F. Garcia Ferré et al. – *CORROS SCI* – 2013

## Radiation tolerance

### Interstitial emission from GBs

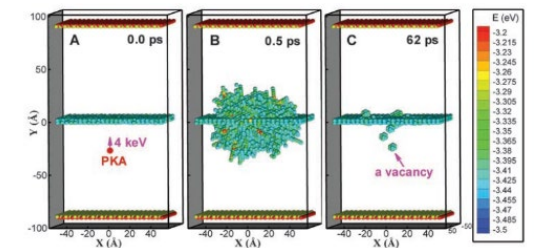

X.M. Bai et al. – *Science* – 2010

# PLASTICITY PRESERVED BEYOND THE NANOSCALE?

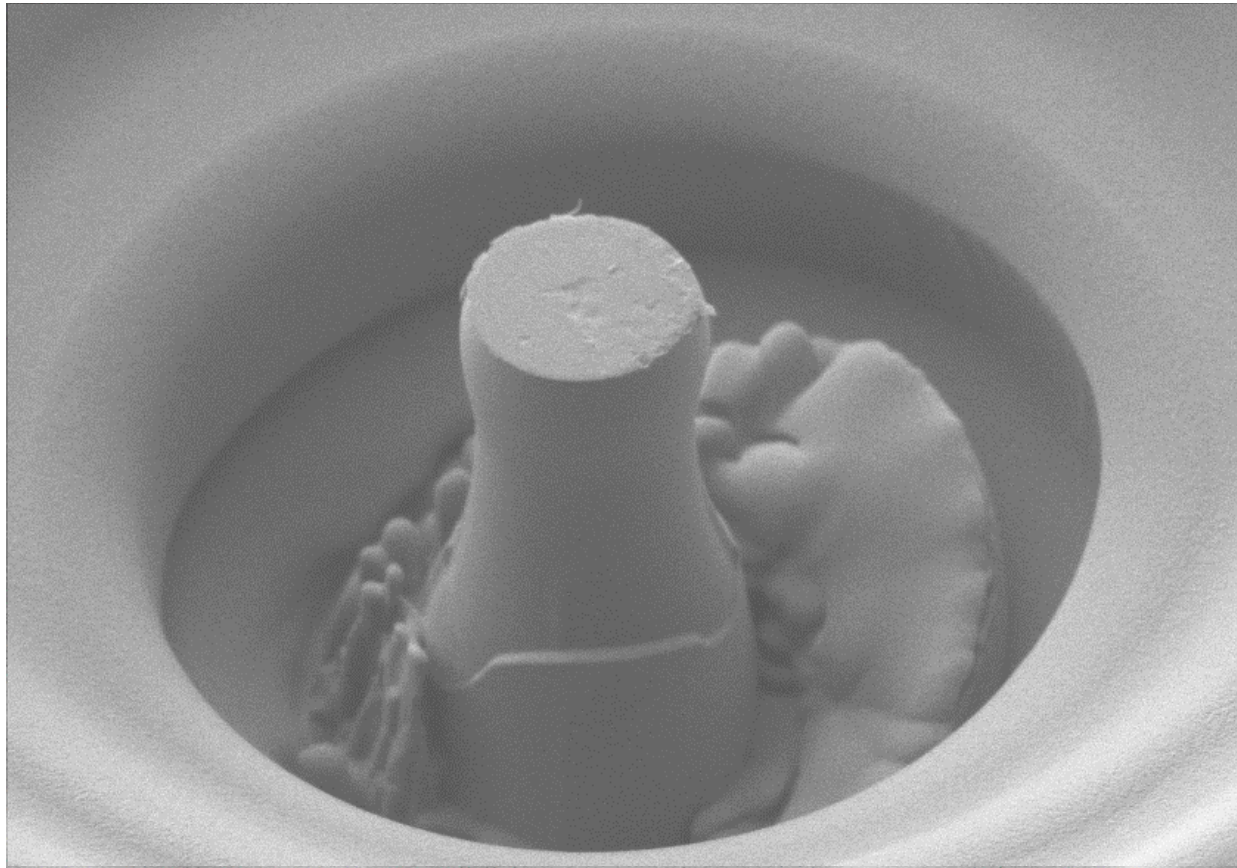

EHT = 1.00 kV  
WD = 4.9 mm  
Signal A = SE2

Tilt Angle = 36.0 °  
Tilt Coor. = Off  
Mag = 7.00 KX  
ESB Grid is = 1048 V

Stage at T = 45.0 °

Date: 10 Jun 2020  
Time: 10:22:23



TAMPERE UNIVERSITY OF TECHNOLOGY





DEASCUOLA

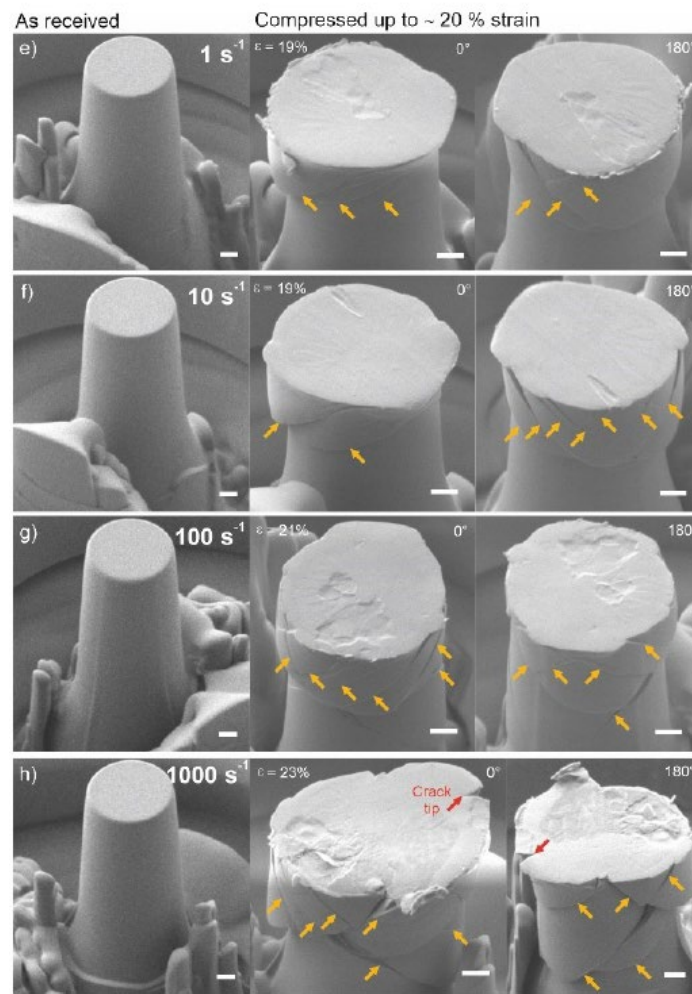
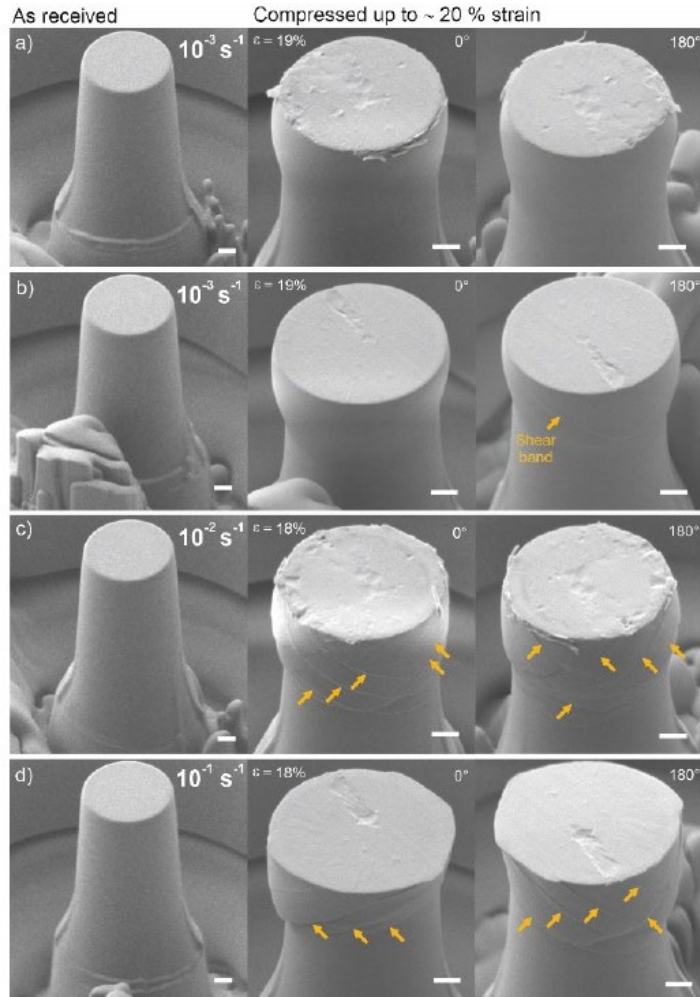

per le  
scuole

# PLASTICITÀ PRESERVATA SU MICROSCALA AD ALTE VELOCITÀ DI DEFORMAZIONE

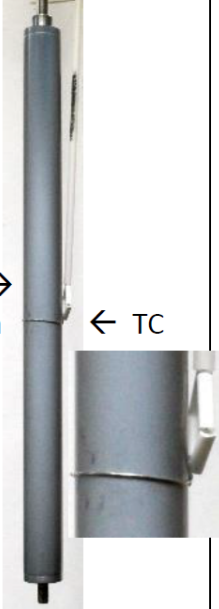
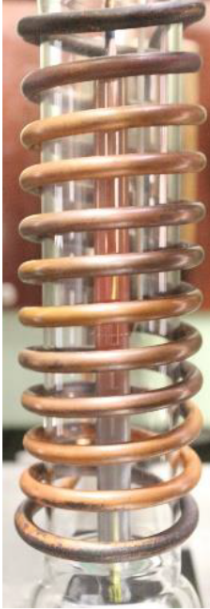

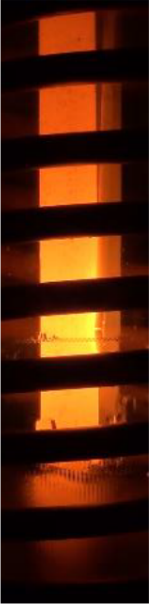
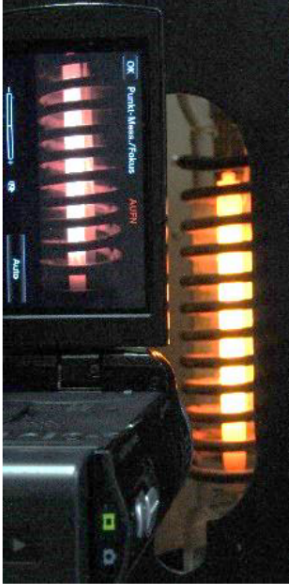
 <p>Pyro- meter → position ← TC</p>			 <p>← Upper rim of quench glass  ← Water level</p>	
<p>Sample with TC attached</p>	<p>Sample inside the quartz tube of the QUENCH-SR facility</p>	<p>Test 220808a running</p>	<p>Test 220809a: Quenching in progress</p>	<p>Video recording of test 220808a</p>

Bottom

Top

As deposited, pristine  
sample



1400°C Transient, Cooled-down



1500°C Transient, Water quenched



1400°C Isothermal, Cooled-down



1300°C Isothermal, Water quenched



1200°C Isothermal, Water quenched



# ISOTHERMAL OXIDATION IN STEAM AT 1200°C – 1H



Mirco Grosse

Karlsruher Institut für Technologie

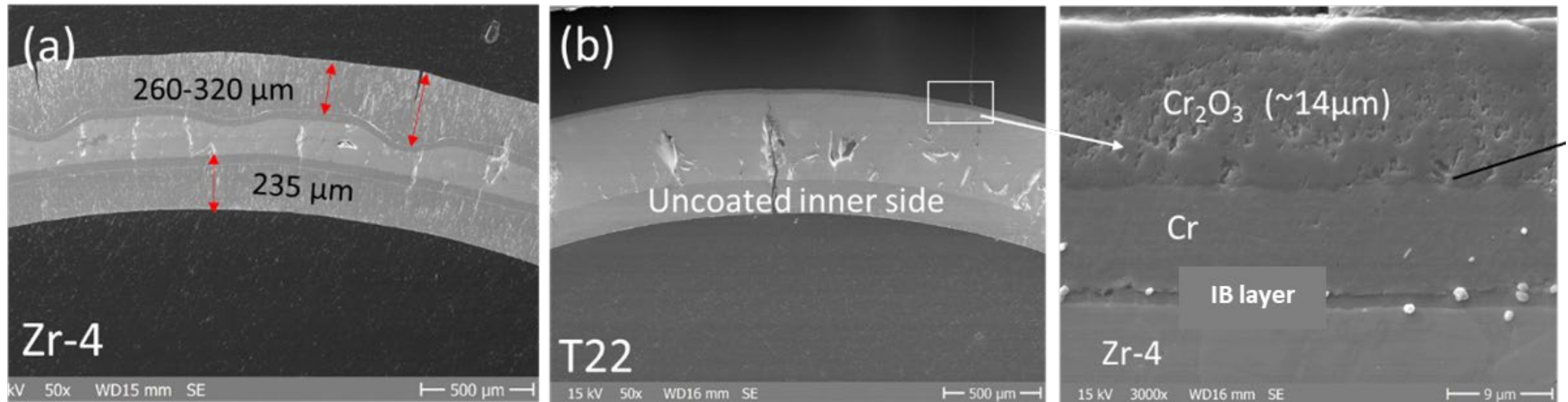

- Le superfici di due campioni rivestiti sono state trasferite in un colore verde, indicando la crescita di uno strato di  $\text{Cr}_2\text{O}_3$ . Non è stata osservata alcuna spallazione del rivestimento dopo l'ossidazione per entrambi i campioni rivestiti.
- NESSUNA interdifferenza tra Cr e Zr alla scala di temperatura e tempo rilevante per LOCA

# Reattori nucleari di IV generazione



DEASCUOLA



**a2a**  
LIFE COMPANY

per le  
scuole

# REATTORI VELOCI AL PIOMBO: UN CONCETTO A SICUREZZA INTRINSECA

## ALFRED (demonstrative LFR) overview

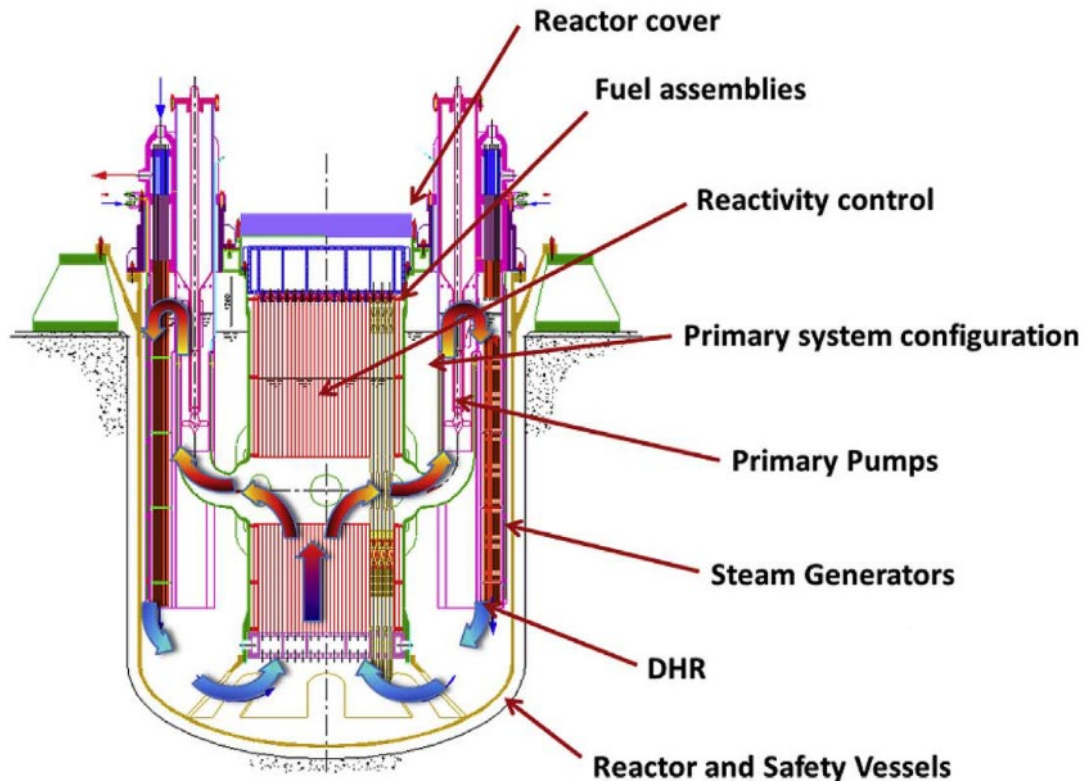

### ➤ Vantaggi sfruttabili:

- Ciclo ad alta efficienza
- trasmutazione degli elementi di scarto (combustione)
- Allevamento di combustibile fertile

### ➤ Benefici apportati dal piombo:

- chimicamente inerte
- buone proprietà termiche, fisiche e nucleari
- Schermatura dalle radiazioni

### ➤ Condizioni di lavoro per le LFR:

- 150 dpa
- 550 °C (up to 800 °C)
- **NESSUN MATERIALE ADATTO A CAUSA DELLA CORROSIONE**

# Fusione



DEASCUOLA



a2a  
LIFE COMPANY

per le  
scuole

# IL SANTO GRAAL DELLA PRODUZIONE DI ENERGIA: LA FUSIONE NUCLEARE

DEMO (demonstrative fusion power plant)

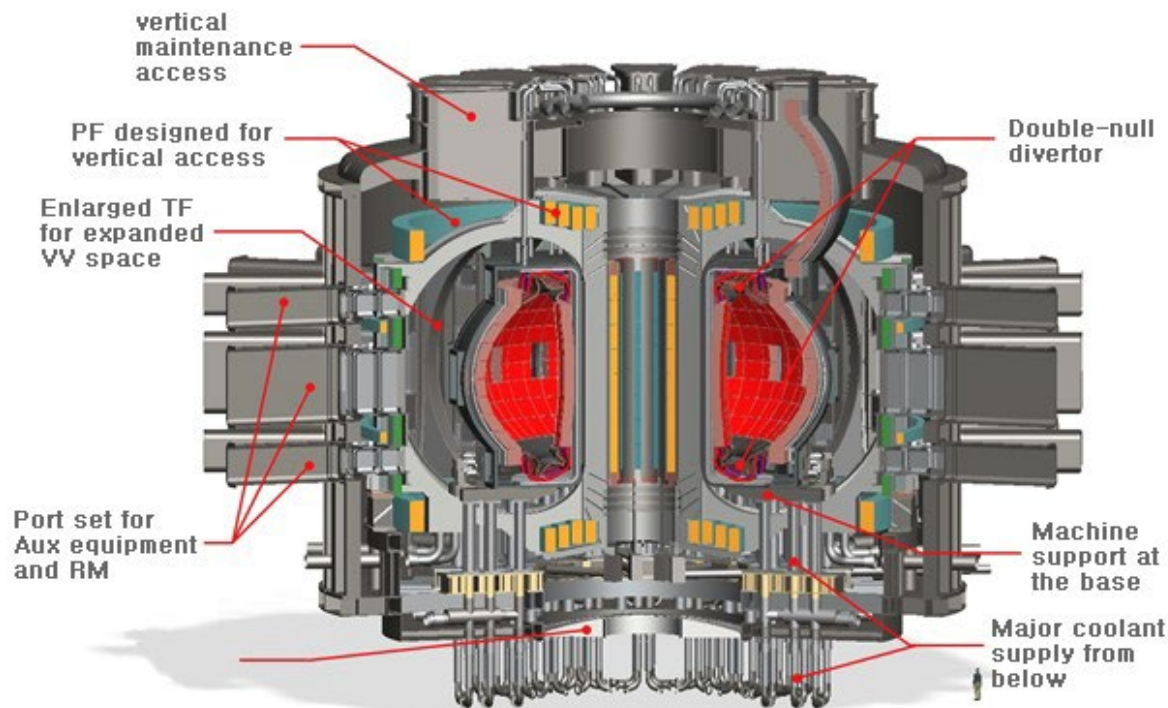

▲ K-DEMO TOKAMAK (OPTION II)

<https://energyfutureslab.blog/>

## ➤ Vantaggi sfruttabili:

- combustibile verde e più sicuro come gli isotopi H (D e T) o He
- nessun consumo di metalli pesanti, né produzione di rifiuti
- quantità (quasi) illimitata di combustibile per la reazione di fusione
- nessun rischio di proliferazione (nessun Pu, U, Th coinvolti)

## ➤ Condizioni di lavoro per la fusione:

- Fino a 200 dpa
- il funzionamento T [°C] dipende strettamente dal singolo componente del reattore

# IL SANTO GRAAL DELLA PRODUZIONE DI ENERGIA: LA FUSIONE NUCLEARE



generalfusion

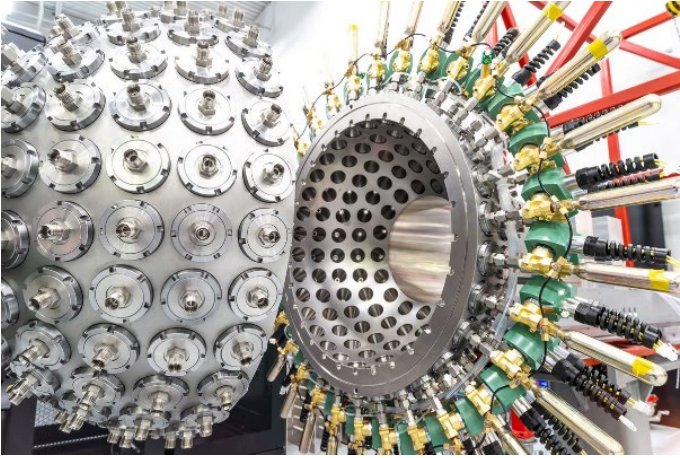
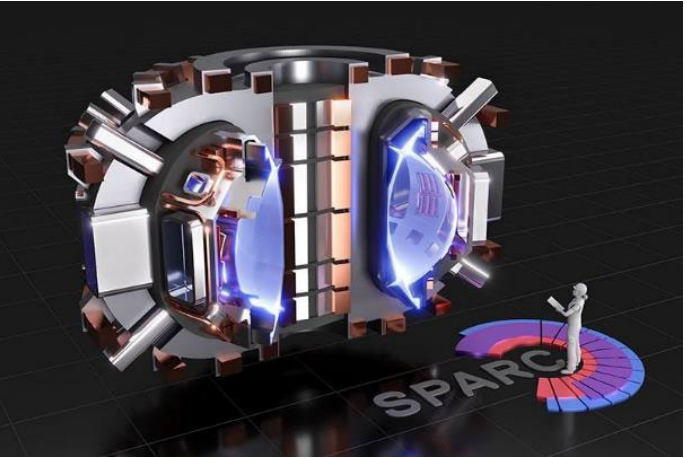

Wendelstein 7-X

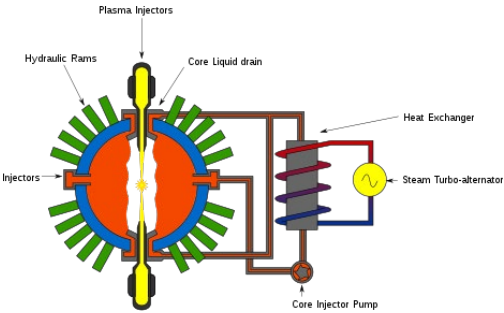
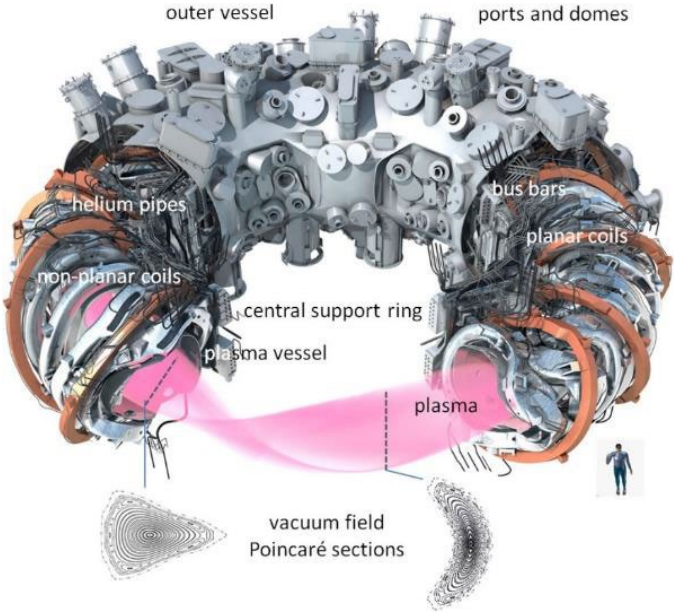

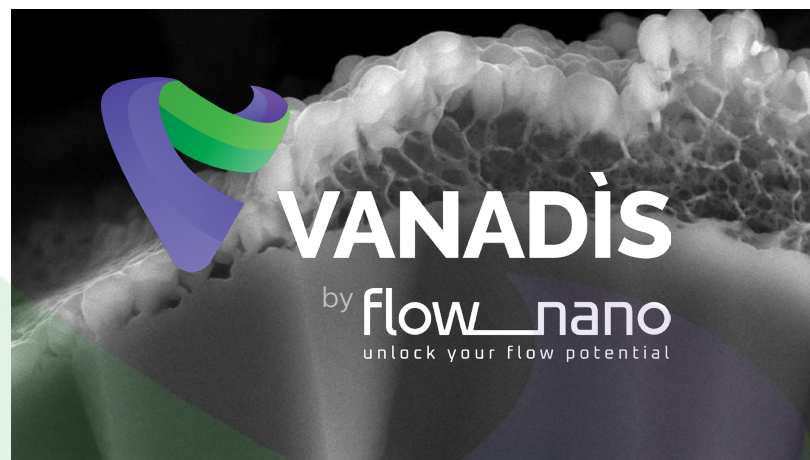

# Vanadium redox flow batteries **ELECTRODES** for Utility-Scale Long Duration Energy Storage

We unlock the Vanadium Redox Flow Batteries potential to make the energy transition possible

# TRANSIZIONE ENERGETICA: NUOVE TECNOLOGIE PER LE FONTI DI ENERGIA RINNOVABILE INTERMITTENTI

Enabling the **EU Green Deal** requires the adoption of innovative technologies in the global and European markets.

We need to achieve:

- **Climate neutral continent** by 2050
- **55% less net greenhouse gas** emission by 2030
- Cut European's dependency on gas by 2030

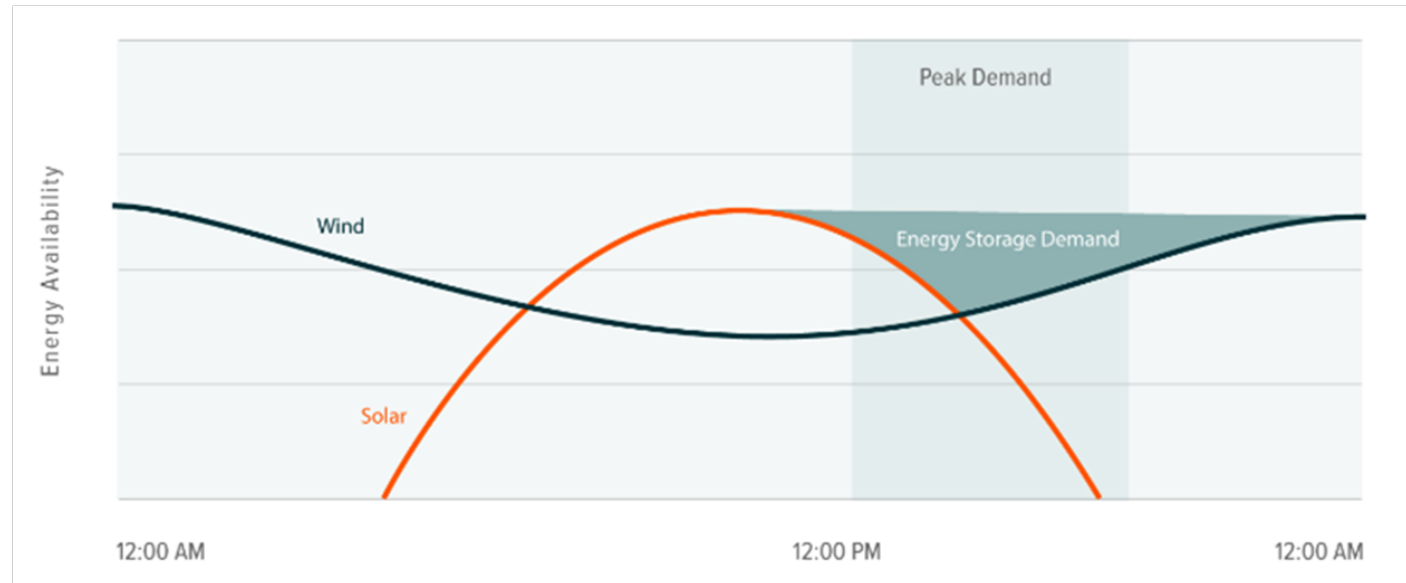

Source: Global X ETFs – Lawson A. (2019) Maintaining electric reliability with wind and solar sources



# LONG DURATION ENERGY STORAGE (LDES) IS KEY TO ACHIEVE THE DECARBONIZATION OF THE ENERGY SECTOR

- Per consentire una penetrazione del 40% di energia rinnovabile, LDES (8+ h) è essenziale
- Per garantire il >90% di elettricità annua da eolico e solare sulla rete, è necessario uno stoccaggio di lunghissima durata (24+ ore)
- Le soluzioni attuali (batterie agli ioni di litio, accumulo idroelettrico di pompaggio, accumulo di energia ad aria compressa) hanno limitazioni: durata dello stoccaggio, costi, impronta ambientale, densità energetica

Maximum required storage duration  
(hours at rated power)

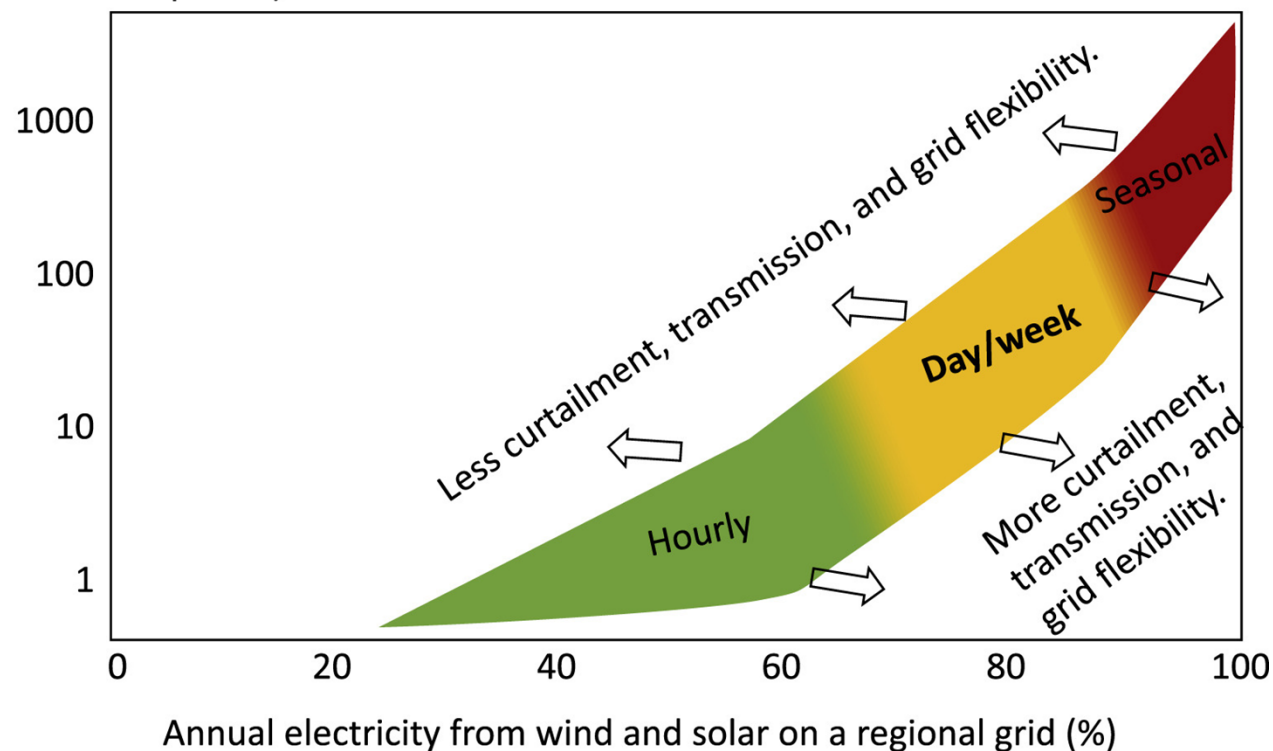

# VANADIUM REDOX FLOW BATTERIES (VRFB)

## BATTERIE A FLUSSO SONO LA SOLUZIONE PIÙ PROMETTENTE PER LDES

Una **batteria a flusso** è un tipo di batteria ricaricabile in cui gli elettroliti - fluidi conduttori contenenti ioni di vanadio - fluiscono attraverso una cella elettrochimica che converte l'energia chimica direttamente in energia elettrica (in un processo di riduzione-ossidazione), attraverso i lati separati di una membrana a scambio protonico (pila). Gli elettroliti sono generalmente immagazzinati in serbatoi e vengono pompati attraverso le celle del reattore fino alla pila. Lo scambio ionico all'interno della cella (così come il flusso di corrente elettrica verso un circuito esterno) avviene attraverso la membrana degli elettrodi, mentre entrambi i fluidi circolano nel proprio spazio.

Tuttavia, la tecnologia **VRFB** è ancora agli inizi, principalmente a causa del costo elevato rispetto alla batteria agli ioni di litio.

Il fattore limitante dei costi più grave è la bassa densità di corrente a cui operano i VRFB - 100 mA/cm<sup>2</sup>

Gli elettrodi sono il luogo in cui l'energia immagazzinata nell'elettrolita viene convertita in energia elettrica. Le caratteristiche principali degli elettrodi sono l'area superficiale specifica e l'attività elettrochimica: più alta è, meglio è.

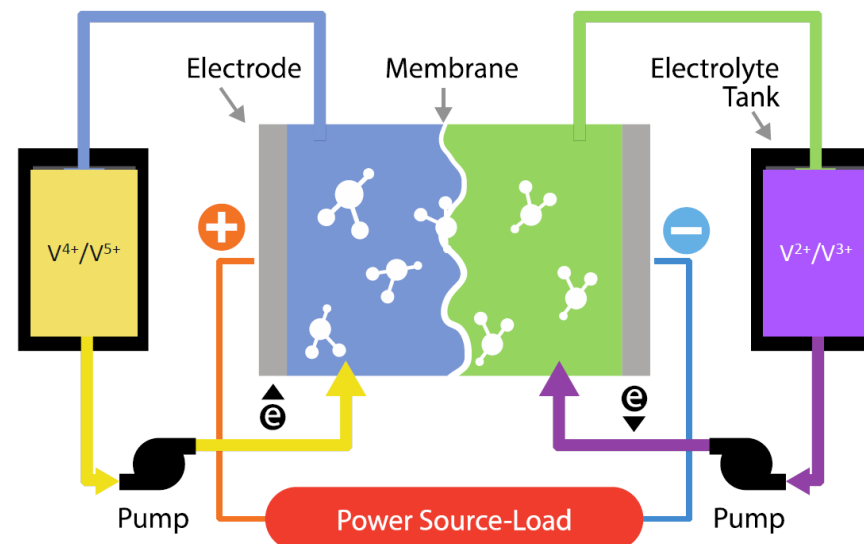

- ENERGY AND POWER ARE DECOUPLED
- UTILITY SCALE LONG DURATION ENERGY STORAGE (6-10 h)
- NO SAFETY ISSUE (WATER-BASED CHEMISTRY)
- REUSABLE RAW MATERIALS (VANADIUM RENTING MODEL)
- LONG CYCLE LIFE (20.000 CYCLES)

# FLOW-NANOJED TECHNOLOGY

## Deposizione di particelle di nanoC

Le nanoparticelle di carbonio idrogenate (HCNP) vengono depositate sulle fibre di carta carbone dell'elettrodo attraverso una sorgente di deposizione a getto di nanoparticelle potenziata al plasma (NANOJED), formando un film mesoporoso sulla superficie.

## Post-trattamento termico

L'HCNP subisce un trattamento di ricottura termica sotto vuoto (fino a 1000°C), convertendole in nano cipolle di carbonio turbostratiche (TCNO) con un diametro da 5 a 15 nm.

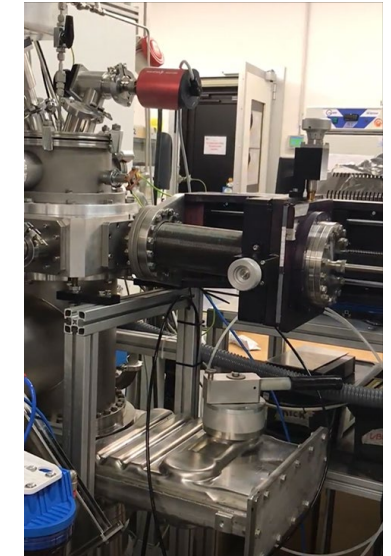
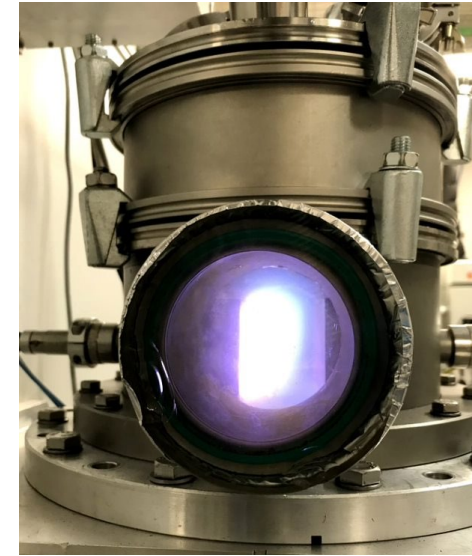
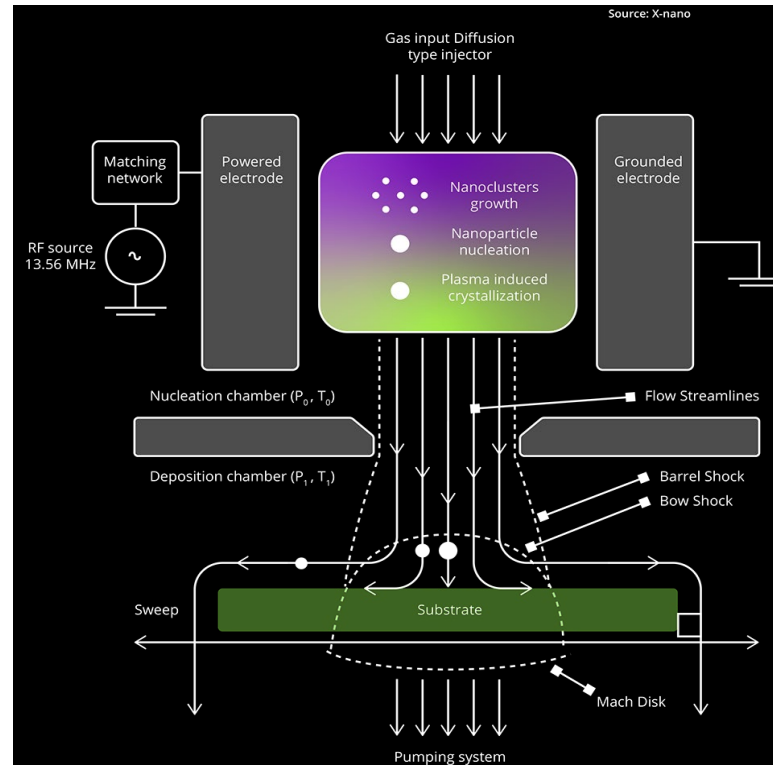

**2 FAMIGLIE DI BREVETTI, 7 BREVETTI CONCESSI, 5 BREVETTI IN CORSO**

**"Metodo e apparato per la deposizione di strati sottili nanostrutturati a morfologia e nanostruttura controllata"**

**"Elettrodo per una batteria a flusso e metodo di produzione"**

# ELETTRODI FLOW-NANO PER VRFB

Con la nostra soluzione di elettrodo Vanadis, triplichiamo la densità di corrente, quindi la potenza della batteria, rispetto agli elettrodi standard.

Questo si traduce in:

- densità di potenza in uscita triplicata o
- riduzione del costo unitario della pila di un fattore 3

**Efficienza di andata e ritorno (RTE): 80,7%**

**Densità di corrente: 300 mA/cm<sup>2</sup>**

**Diminuzione RTE per ciclo: 0,004%**

**Durata: Oltre 20 anni (>20000 cicli)**

**Neat Carbon fiber**

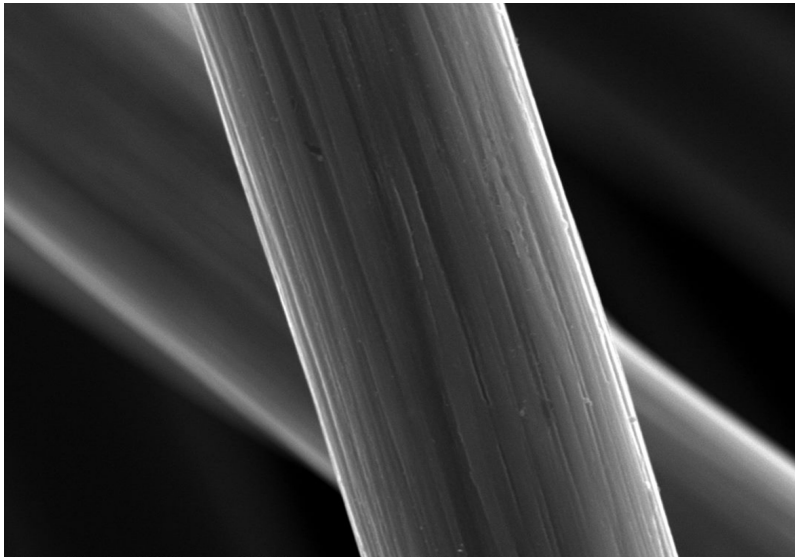

**Coated fiber**

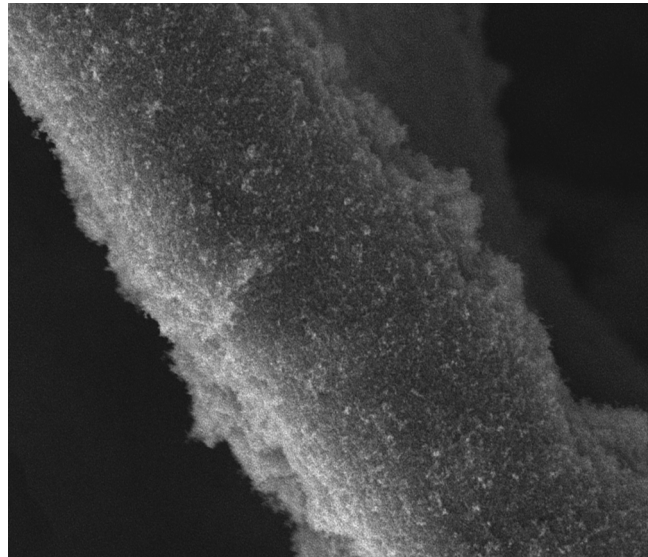

**Turbostratic Carbon nano-onion (TCNO)**

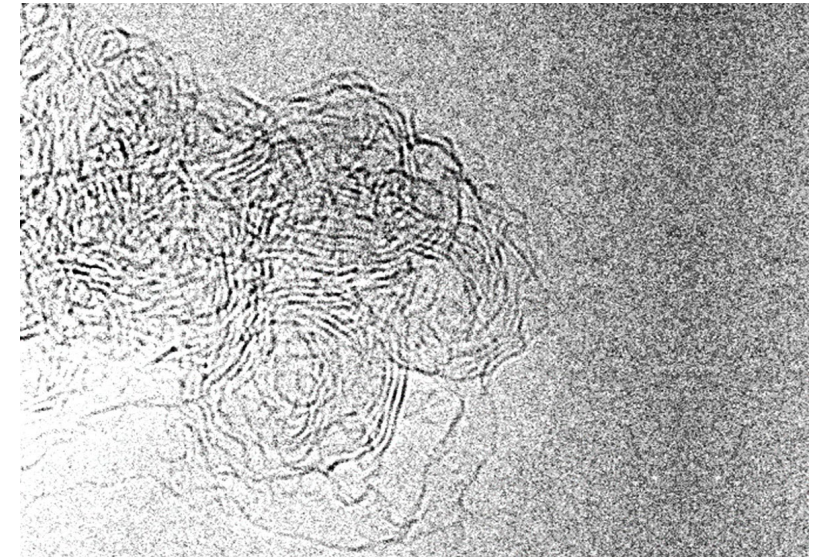

GRAZIE

SPAZIO ALLE DOMANDE

# SCOPRI E ISCRIVITI AI PROSSIMI APPUNTAMENTI

[https://l.deascuola.it/obiettivo\\_2030/index.html](https://l.deascuola.it/obiettivo_2030/index.html)

18.04.2024 / 17:00-18:30

## Net zero: neutralità climatica entro il 2050

Dove siamo e quali azioni mettere in campo.

**Pierpaolo Duce**, Dirigente di ricerca Istituto per la bioeconomia del Cnr.



ISCRIVITI

14.05.2024 / 17:00-18:30

## Sostenibilità e cambiamento climatico

Ognuno può fare la sua parte.

**Serena Giacomini**, fisica climatologa, presidentessa Italian Climate Network  
**Marco Confortola**, Alpinista estremo, explorer.



ISCRIVITI